



NSR-500

Network Surveillance Recording Server

The NSR-500 is Sony's 16-channel Full-HD network surveillance recording server delivering a very good cost-performance ratio.

Depending on system requirements, you can select the best model for your particular application.

Expandability and Flexibility

As shown below, you can choose from two NSR-500 models, and increase the number of hard disk drive (HDD) units to achieve your required storage capacity. RAID levels can also be selected according to your precise requirements for reliability. To expand your choice of future upgrades, the optional NSBK-EB05 Analog Encoder Board and NSBK-DH05 Display Accelerator Board are also available separately. Furthermore, with the optional additional Camera License, you can also add extra cameras.

Number of HDDs	Storage Capacity	Model Number	Configurable RAID Level
0	-	NSR-500	-
1	1 TB (1 TB x 1)	-	-
	2 TB (2 TB x 1)		
2	2 TB (1 TB x 2)	-	RAID 0, RAID 1
	4 TB (2 TB x 2)		
3	3 TB (1 TB x 3)	-	RAID 5
	6 TB (2 TB x 3)		
4	4 TB (1 TB x 4)	NSR-500/4T	RAID 10 (1+0), RAID 5, RAID 5 with hot spare
	8 TB (2 TB x 4)	-	
5	5 TB (1 TB x 5)	-	RAID 5, RAID 5 with hot spare
	10 TB (2 TB x 5)		
6	6 TB (1 TB x 6)	-	RAID 10 (1+0), RAID 5, RAID 5 with hot spare
	12 TB (2 TB x 6)		

OPTIONAL ACCESSORIES (sold separately)

■ Analog Encoder Board NSBK-EB05

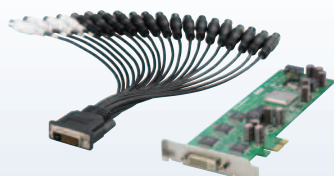

NSBK-EB05

■ Display Accelerator Board NSBK-DH05



NSBK-DH05

■ Additional Camera License for Four Channels NSBK-CL05

■ Hard Disk Drive (1 TB) NSBK-HS05:01

■ Hard Disk Drive (2 TB) NSBK-HS05:02

■ System controller RM-NS1000



RM-NS1000

FEATURES

Long-duration Recording

With a 12-TB HDD (2-TB x 6), you can record up to 300 hours of high-quality Full-HD images of 16 channels compressed at 4 Mbps with a frame rate of 30 fps.

RAID Technology to Prevent Disk-failure Data Loss

The hard disk storage units of the NSR-500 are configured with high redundancy.

They feature RAID implementations and hot-swappable capabilities to protect important data against hard disk failure, 24 hours a day. You can choose from RAID 0, RAID 1, RAID 10 (1+0), RAID 5, or RAID 5 + Hot Spare, depending on your system requirements.

Ideal Replacement for Existing Digital Video Recorders

With the optional NSBK-EB05 Analog Encoder Board (sold separately), the NSR-500 can replace digital video recorders (DVRs) in a CCTV surveillance system, which can be used with existing analog cameras.

The NSR-500 is a relatively small investment, equivalent to a DVR purchase, yet it provides you with the opportunity to gradually migrate to a network surveillance system in future.

Optional Licenses for Future System Expansion

The optional NSBK-CL05 (sold separately) allows you to add extra licenses, and you can connect up to 24 network cameras to a single NSR-500 (including the original 16 cameras).

Easy Setup and Easy Operation

The NSR-500 detects Sony's network cameras in a network and sets up all the parameters of each camera in a step-by-step manner with a dedicated setup wizard. This drastically reduces the time required for system installation. Images from cameras are assigned automatically to a monitor layout menu, so that you can start monitoring instantly.

Backward System Compatibility

The NSR-500 can be used with Sony's existing recording systems such as the NSR-1000 Series, and RealShot Manager Advanced, through the RealShot Manager Advanced client - software that can be downloaded from the NSR-500.

SYSTEM EXAMPLES

Stand Alone Configuration

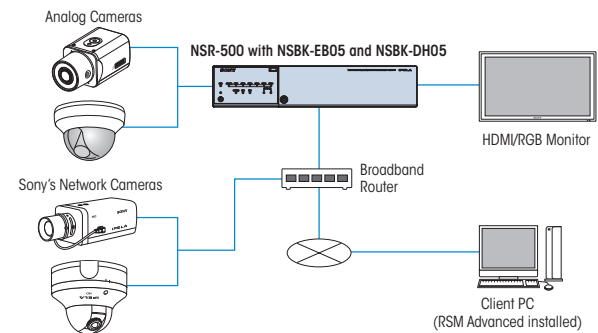

Multi-location System

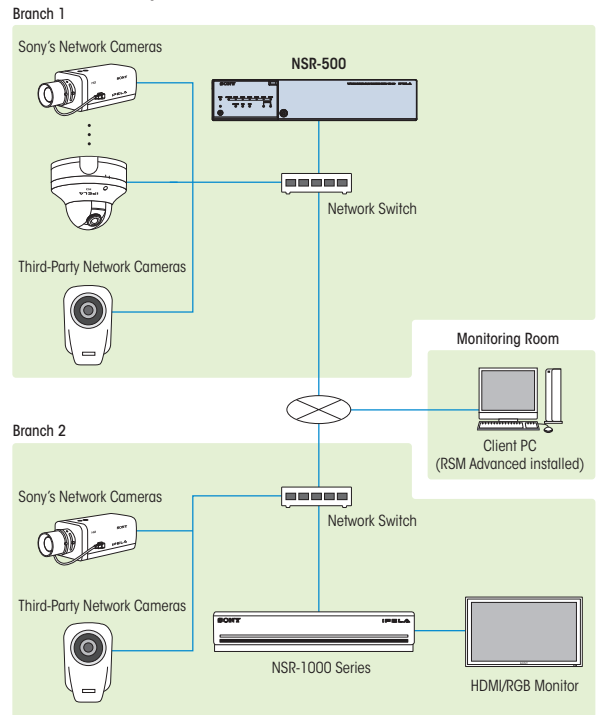

CONNECTORS

Front Panel NSR-500

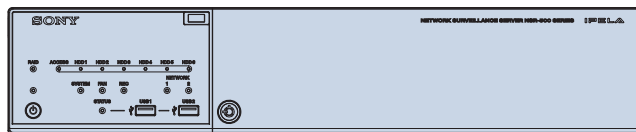

Rear Panel NSR-500 with NSBK-EB05 Analog Encoder Board

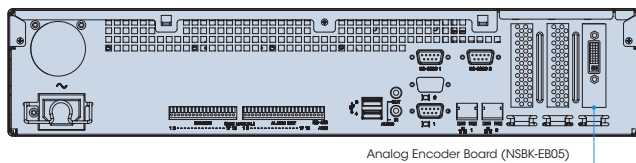

Rear Panel NSR-500 with NSBK-DH05 Display Accelerator Board

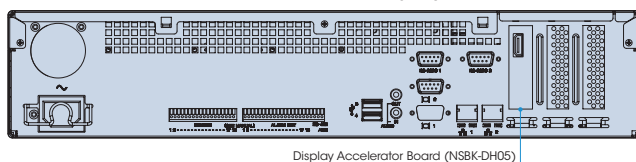

SPECIFICATIONS

NSR-500	
Recording	
Number of Cameras Supported	16 (Max. 24 with NSBK-CL05)
Total Recording Frame Rate	Max. 480 fps (Max. 64 Mbps)
Maximum Recording Frame Rate/Camera	Max. 30 fps/camera
Video Recording Format (IP Camera)	H.264, MPEG-4, JPEG
Audio Recording Format (IP Camera)	G.711, G.726
Number of Hard Disk Drives	NSR-500: None NSR-500/4T: 4 disks
Hard Disk Drive (Physical Capacity)	Expandable up to 12 TB (2 TB x 6) NSR-500: None NSR-500/4T: 4 TB (1 TB x 4)
Hard Disk Drive (Interface)	SATA
Hard Disk Drive (RAID Level)	RAID 0, RAID 1 RAID 10 (1+0), RAID 5, RAID 5 with hot spare
Hard Disk Drive (Recording Capacity)	NSR-500: None NSR-500/4T (default setting: RAID 5): Approx. 2.6 TB
Expansion Storage	iSCSI storage (Max. 16 TB)
Video Output	
Monitor Output (Interface)*1	Analog RGB (D-sub 15-pin) (x1)
Monitor Output (Display Resolution)	1920 x 1200, 1920 x 1080, 1360 x 768, 1600 x 1200, 1280 x 1024, 1024 x 768
Display Frame Rate (Live)	Varies depending on system configuration
Display Frame Rate (Playback)	Varies depending on system configuration
Interface	
Network Port	1000BASE-T, 100BASE-TX, 10BASE-T (RJ-45) (x2)
Serial Interface (for UPS)	RS-232C: D-sub 9-pin (x1)
USB	USB 2.0 (x4)
Sensor Input	Compatible with DC 3.3 V to 24 V photo coupler input (x8)*2
Alarm Output	Max. 24 V DC/1 A, mechanical relay output (x8)*2
Monitor Output*1	Analog RGB (D-sub 15-pin) (x1)
Audio Line Output	Stereo mini jack (x1)
General	
Power Requirements	100 V to 127 V AC, 200 V to 240 V (50/60 Hz)
Power Consumption	Max. 250 W (100V to 240 V/3.5 A to 1.5 A)
Operating Temperature	41°F to 104°F (5°C to 40°C)
Operating Humidity	20% to 80% (no condensation)
Dimensions (W x H x D)	17 3/8 x 3 1/2 x 15 1/2 inches (440 x 89 x 392 mm) (2U) (excluding protrusions)
Weight	15 lb (6.8 kg) (NSR-500)
Supplied Accessories	Installation manual (1) CD-ROM (User's Guide) (1) Flyer (WEEE) (1) Flyer (EU battery) (1) Warranty booklet (1) HDD cover key (2) Rubber feet (4) HDD screw (24) (NSR-500:00 only) DVD-ROM (Setup Program) (1) (NSR-500:00 only) Warranty Sheet Accessory (1) (J model only) AC Power code (1) (J/CN model only)
Optional Accessories (sold separately)	NSR-RAIL rack mount kit

*1: Monitor Output is designed for use in system configuration settings, not for live monitoring applications. Display frame rates for live viewing and playback vary according to system configurations.

*2: Insulated from the main unit.

NSBK-EB05	
Video/Audio	
Number of analog input	Video input (x16)/Audio input (x4)*3
Input video format	NTSC
Video codec	H.264/JPEG
Motion detection	Yes
Noise reduction	Yes
Video resolution	NTSC: 720 x 480, 720 x 240, 704 x 480, 704 x 240, 352 x 240
Maximum frame rate	NTSC: 30 fps/camera (total 480 fps)
Video quality	Bitrate: 64 Kbps to 2 Mbps (H.264) Quality: Low, Medium, High, Highest (JPEG)*4
Audio codec	G.711, 64 Kbps
Interface	
Input connector (by supplied cable)	Video input connector (cable) Audio input connector (cable)
	BNC (x16) (black) RCA (x4) (white)
General	
Operating temperature	41 to 104 °F (5 to 40 °C)
Operating humidity	20 to 80%
Dimensions (Board)	Approx. 7 5/8 x 2 3/4 inches (192 x 69 mm) (exclusive projections)
Weight	Board: Approx. 3.5 oz (100 g) Cable: Approx. 8.5 oz (240 g)
Supplied accessories	Analog video/audio input cable (1), Installation manual (1), Warranty booklet (1)

*3: The audio channels from No. 1 to No. 4 are allotted the video channels 1 to 4 respectively.

*4: When using a JPEG format, the total frame rate for the system is decreased to 240 fps in High quality mode and 160 fps in Highest quality mode.

NSBK-DH05	
Video/Audio	
Maximum Decoding Resolution	Up to 1,920 x 1,080
Video Decoding Format *5	H.264/MPEG-4
Monitor Output (Display Resolution)	1920 x 1200 (not supported by HDMI)/1920 x 1080/1360 x 768/1600 x 1200/1280 x 1024/1024 x 768
Display Frame Rate	Max. 60 fps (30 fps x 2 channels) at 1920 x 1080 at 4 Mbps Max. 60 fps (15 fps x 4 channels) at 1920 x 1080 at 4 Mbps Max. 120 fps (30 fps x 4 channels) at 1280 x 720 at 2 Mbps Max. 135 fps (15 fps x 9 channels) at 1280 x 720 at 2 Mbps Max. 270 fps (30 fps x 9 channels) at 720 x 480 at 1 Mbps Max. 240 fps (15 fps x 16 channels) at 720 x 480 at 1 Mbps
Interface	
Monitor Output *6	HDMI (x1), analog RGB (D-sub 15-pin) (x1)
Audio Output	1 channel (HDMI) *7
General	
Operating Temperature	41°F to 104°F (5°C to 40°C)
	20% to 80%
	6 3/4 inches x 3 1/4 inches x 1 1/8 inches (170 mm x 80 mm x 27 mm) (exclusive projections)
	5 oz (130 g)
	Analog RGB cable (for internal wiring) (1), Connector cover (1), Installation manual (1), Warranty booklet (1)

*5: Either the HDMI or analog RGB interface can be used.

*6: When using the HDMI interface, the alarm sound (beep tone) may not be properly produced (this depends on the monitor connected). If so, please use the NSR-500's audio line output.

NSBK-DH05										
Display Resolution	Maximum Number of Monitor Frames									
1920 x 1080	0	0	0	0	0	0	0	0	0	0
1280 x 720	0	1	2	3	4	5	6	7	8	9
720 x 480	16	15	13	11	9	7	5	3	1	0
1920 x 1080	1	1	1	1	1	1	1	1	1	1
1280 x 720	0	1	2	3	4	5	6	7		
720 x 480	14	12	10	8	6	4	2	0		
1920 x 1080	2	2	2	2	2	2				
1280 x 720	0	1	2	3	4	5				
720 x 480	10	8	6	4	2	0				
1920 x 1080	3	3	3	3	4	4				
1280 x 720	0	1	2	3	0	1				
720 x 480	6	4	2	0	2	0				