

CNB-GN600/GP600

WDR DAY&NIGHT COLOR CAMERA



Features

- 1/3 inch SONY Double Scan CCD
- Day&Night (IR Cut Filter Removable)
- WDR (Wide Dynamic Range)
- Digital Slow Shutter (0.001 Lux)
- 3x Digital Zoom, AGC, BLC, Flickerless On/Off
- Privacy Zone, OSD (On Screen Display)
- Remote Control (RS-485 Interface)

Rear View



OPTION MODEL

- CNB-GN605/GP605 : AC24V/DC12V Dual Voltage Model
- CNB-GN610/GP610 : Without Day&Night Function Model
- CNB-GN600TP/GP600TP : UTP Transmitter Model
- CNB-GN610TP/GP610TP : Without Day&Night, UTP Transmitter Model

CNB-GN605/GP605



DIMENSIONS

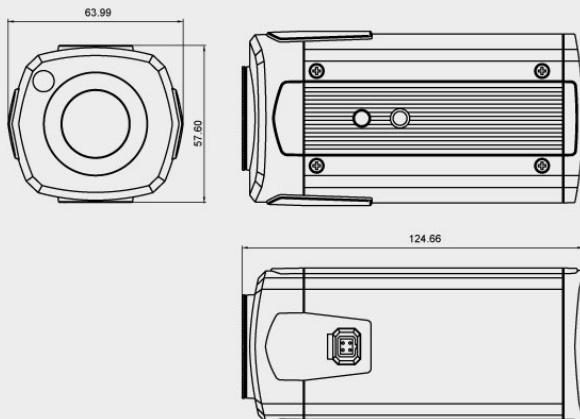

SPECIFICATIONS

Model	CNB-GN600	CNB-GP600
Signal System	NTSC : 525 Lines	PAL : 625 Lines
Scanning System	2:1 Interlace	
Scanning Frequency(H)	15.734 KHz	15.625 KHz
Scanning Frequency(V)	59.94 Hz	50 Hz
Sync System	Internal	
Image Sensor	1/3 inch SONY Double Scan CCD	
Total/Effective Pixels No.	410K/380K	470K/440K
Iris Mode	Video/DC	
S/N Ratio	More than 48dB (AGC Off)	
Resolution	Horizontal : 480 TV Lines	
Video Output Level	1.0 Vp-p (75 Ohms, Composite)	
Min. Illumination	Day (0.3 Lux), Night (0.1 Lux), DSS (0.001 Lux)	
WDR(Wide Dynamic Range)	On/Off	
Day&Night(ICR)	Auto/Day/Night	
Digital Zoom	3x	
Digital Slow Shutter	Off / 2FLD~20FLD / 40FLD / 80FLD / 160FLD Mode	
Shutter Speed	1/60 ~ 1/10,000 Sec	1/50 ~ 1/10,000 Sec
White Balance	Auto / Hold / Manual	
AGC/BLC/Flickerless	On / Off	
Camera ID/Zone Label	On / Off	
Mirror/Freeze/Negative	On / Off	
Supplied Voltage	DC 9V ~ 15V (Recommendation DC 12 ± 0.5V)	
Power Consumption	Max. 4.0W / 330mA	
Dimensions(WxHxD)	63.9 x 57.6 x 124.6mm	
Weight	Approx. 430g	