

# JVC®

1/3" CCD COLOUR VIDEO CAMERA

## TK-C8301RE TK-C2301WPRE

14-bit  
processing

### SuperLoLux 2™

COLOUR IN VIRTUAL ZERO LUX



When the light fails,  
our cameras won't.

600 TV Lines / IR LED / Compact Design



#### High-Resolution of 600 TV Lines

Newly developed 14-bit DSP enables industry-leading high quality pictures

#### Super LoLux 2™ Sensitivity

0.05 lx at colour mode (50% video level, F1.2, AGC HIGH)  
0.03 lx at B&W mode (50% video level, F1.2, AGC HIGH)  
0 lx (with IR LED)

#### Industry-leading S/N Ratio of 52dB

#### ExDR Plus – Advanced Wide Dynamic Range

JVC-original technology to reproduce clearer images for both bright and dark areas

#### Clear 5 Meter IR LED

Ideal for installation near entrances with diffusion type IR LED enabling exposure without halation

#### 3D Noise Reduction

Powerful system to reduce noise in dark environments

#### Area White Balance

New function that can apply Auto White Balance to a specific area

#### Auto Black Adjustment

Intelligent adjustment for dark areas to provide images without black out

#### Fine Focus Adjustment Technology

Newly developed mechanism for finer and more accurate focus adjustment

#### Outdoor-Ready Vandal and Tamper Proof Design (IP66 Compliant)\*

\*TK-C2301WPRE

#### An Array of Features to Suit Any Environment

- Automatic Gain Control (AGC)
- Automatic Electronic Shutter (AES)
- 4 Area Patterns for Backlight Compensation (BLC)
- Up to 128x Slow Shutter
- Intelligent Black Level Adjustment avoiding black out of dark areas
- Manual and Auto Tracking White Balance
- 1.2x/2.0x Digital Zoom
- Privacy Mask for protecting intrusive monitoring
- Display Mode Selection for CRT and LCD
- CCD White Spot Compensation
- Focus Adjustment Mode for accurate focusing
- Triple Axis Rotation for flexible lens angle adjustment
- Optional heater unit for use at low temperatures of down to -30°C (-22°F)
- 24VAC/12VDC Dual Voltage

# Reliable Day & Night Surveillance with High-Resolution Images and Precise Colour Reproduction

## Super LoLux 2™ "COLOUR IN VIRTUAL ZERO LUX"

This camera has been designed to assure precise colour reproduction in low light situations. It is possible to identify image colours in darker places.



Normal camera



JVC Super LoLux 2™

## Clear 5 Meter IR LED

Equipped with an IR LED light tuned for optimal results in observing scenes at a distance of up to 5 meters, such as entranceways. This dispersion type light illuminates a wide area and exposes subjects that are at close range including people, without white-out reflection.



Normal strong IR LED



JVC Clear 5 Meter IR LED

## ExDR Plus

ExDR (Extended Dynamic Range) Plus function is able to clearly display people and characters in the foreground even when they're up against an extremely brightly lit background. And to make the dark parts of the image more clearly visible, it combines Dual Shutter with AGC function to achieve optimal image quality throughout the entire picture.



Normal image



ExDR Plus

## Fine Focus Adjustment Technology

For assisting focusing to the finest point, the Variable-Focal lens now incorporates a newly developed focus gear mechanism (Patent Pending).



### New "Fine Adjust" mechanism

With a very subtle movement, finer, more accurate adjustment is possible. Normal Focus ring lock screw possible.

Patent Pending

## Specifications

	TK-C8301RE	TK-C2301WPRE
Camera		
Signal system	PAL	
Image device	1/3 type IT CCD	
No. of effective pixels	440,000 (752H x 582V)	
Sync system	Internal	
Scanning system	2:1 interlace, 625 lines	
Scanning frequency	15.625kHz (H), 50Hz (V)	
Video output	Composite video signal: 1.0V (p-p), 75 ohms (BNC)	
Video S/N ratio	52 dB (AGC off)	
Horizontal resolution	600 TV lines	
Minimum illumination (typical)	0.05 lx (50%, F1.2, AGC HIGH) 0.025 lx (25%, F1.2, AGC HIGH)	
B&W mode	0.03 lx (50%, F1.2, AGC HIGH) 0.015 lx (25%, F1.2, AGC HIGH) 0 lx (with IR LED ON)	0.006 lx (50%, F1.2, AGC HIGH) 0.003 lx (25%, F1.2, AGC HIGH) 0 lx (with IR LED ON)
Iris control	DC iris	
White balance	ATW (wide/narrow) / AWC / Manual	
ATW colour temp. range	2300K to 10,000K	
Day/Night	True D/N with IR cut-off filter	
Wide dynamic range function	ExDR (by dual shutter)	
3DNR	NORMAL / HIGH	
Display mode (Monitor type)	CRT / LCD1 / LCD2	
BLC	ON / OFF (4 patterns)	
AGC	HIGH / MID / OFF	
Sensitivity-up	off / x2 to x128	
Digital zoom	x1 / x1.4 / x2	
Privacy mask	4 areas	
Focus adjustment mode	Yes	
Lens		
Focal length	2.8mm to 10.5mm, 3.75x vari-focal	
Angle of vision	100 (H) x 73 (V) to 24 (H) x 21 (V)	
Aperture ratio	F1.2 (f=2.8mm) to F3.6 (f=10.5mm)	
Angle adjustment range	—	
IR LED	12 LEDs, 20m	
General		
Power supply	24VAC (50Hz/60Hz) / 12VDC	
Power consumption	320 mA	320mA without optional heater, 1.1 A including heater
Operating temperature range	-10°C to 50°C	
		-10°C to 50°C -30°C to 50°C with optional heater
Dust and water proof	—	
Vandal protection	—	
Dimensions	55mm (W) x 617mm (H) x 175 mm (D)	
Weight (approx.)	360 g	
		1.3 kg

## Dimensions

Unit: mm (inch)

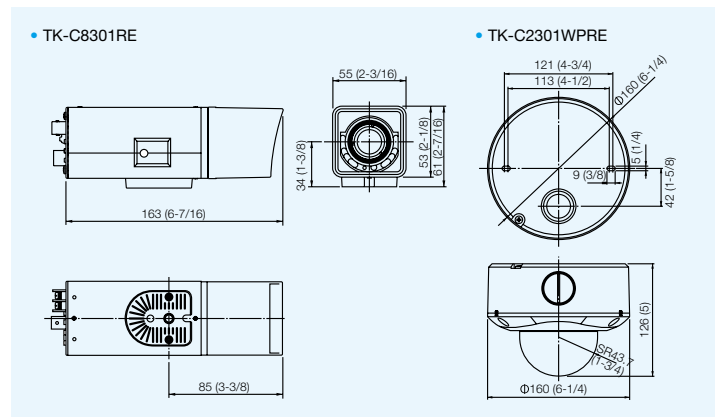

# JVC®