

# AUTODOME IP 5000 HD

www.boschsecurity.com



**BOSCH**

Invented for life



- ▶ Choice of 720p25/30 or 1080p25/30 HD resolution, 30x optical zoom with Bosch's imaging platform specially designed and tuned for accurate color reproduction in scenes with varying lighting levels from day to night
- ▶ Identification of people up to 190 m (623 ft) without loss of any details
- ▶ Simple single cable installation with PoE+ support for indoor/outdoor application
- ▶ High-speed PTZ control for tracking people and vehicles in large indoor/outdoor scene
- ▶ Exceptional low bit rates in static scenes to save the storage cost by up to 50% compared to any equivalent dome in the market

With AUTODOME IP 5000 HD cameras, you can capture full details of your surveillance space while effectively tracking moving targets. The camera uses robust algorithms to ensure the subject stays in full focus when the camera is zooming in or tracking to assist security staff in identifying activity details in the scene. The 30x zoom lens with 720p25/30 or 1080p25/30 HD resolution ensures a sufficient magnification ratio to identify people easily from a distance of up to 190 m (623 ft) for 1080p models and up to 125 m (410 ft) for 720p models.

The AUTODOME IP family, in combination with the Video Security App from Bosch, makes it easier for you to stay in control of your security even when you're on the go. With the camera's built-in Dynamic Transcoding technology, you can easily stream high-resolution H.264 video, pan/tilt/zoom the camera, and search recorded clips remotely through mobile devices such as smart phones or tablets, all on a low-bandwidth network connection (up to 50% less than other H.264 PTZ cameras).

The camera provides complete network-based control of all functionality including pan/tilt/zoom operation, presets, tours, alarms, and web-based configuration of all camera settings.

## Functions

### Superior imaging performance

Designed using Bosch's digital imaging platform, AUTODOME IP 5000 HD cameras deliver high-resolution, zoomed-in views for indoor and outdoor applications with large coverage areas.

### Three (3) pre-programmed user modes

The camera comes with three (3) pre-tuned scene modes to match various lighting conditions found in indoor scenes. Users can complete the configuration without going through multiple imaging settings.

- Indoor: general day-to-night changes without sun highlights and street lighting
- Outdoor: general day-to-night changes with sun highlights and street lighting
- Vibrant: enhanced contrast, sharpness and saturation

**Sodium vapor lamp white balance**

The camera is an exceptional performer when capturing video under a sodium vapor lamp (a street lamp or tunnel lamp, for example). Uncorrected images under these conditions have a yellowish tint, which can make identification difficult. In the Sodium Vapor White Balance mode, the camera automatically compensates for the light from a sodium vapor lamp to restore objects to their original color.

**Superior privacy masking**

For installations in public places where privacy of private property is of high concern, the camera provides 24 individual, easy-to-configure privacy masks, with up to 8 displayed in the same scene. As the camera is zoomed, each mask changes size smoothly and quickly, ensuring that the covered object cannot be seen in most cases.

**PTZ drive and mechanism**

The camera supports 256 pre-positions and two styles of Guard Tours: Preset and Record/Playback. The preset tour has capability for up to 64 pre-positions with a configurable dwell time between pre-positions and can be customized as to the order and frequency each preset is visited. The camera also provides support for two (2) recorded tours, which have a total duration of 15 minutes of movements. These are recorded macros of an operator's movements, including pan, tilt, and zoom activities, and can be played back in a continuous manner. Pan and tilt preset repeatability are accurate to within  $\pm 0.2$  degrees to ensure that the correct scene is captured every time. The camera delivers maximum pan speed of 300 degrees per second and maximum tilt speed of 200 degrees per second. The camera is capable of manual speeds (pan and tilt) of 1 to 120 degrees per second. The camera provides a pan range of up to 360 degrees continuous rotation. The camera's tilt angle is from  $0^\circ$  to  $\pm 90^\circ$ .

**Intelligent Dynamic Noise Reduction reduces bandwidth and storage requirements**

The camera uses Intelligent Dynamic Noise Reduction which actively analyzes the contents of a scene and reduces noise artifacts accordingly. The low-noise image and the efficient H.264 compression technology provide clear images while reducing bandwidth and storage by up to 50% compared to other H.264 cameras. This results in reduced-bandwidth streams that still retain a high image quality and smooth motion. The camera provides the most usable image possible by cleverly optimizing the detail-to-bandwidth ratio.

**Area-based encoding**

Area-based encoding is another feature which reduces bandwidth. Compression parameters for up to eight user-definable regions can be set. This allows uninteresting regions to be highly compressed, leaving more bandwidth for important parts of the scene.

User can configure encoding regions for every configured preset (scene), to increase or decrease the encoding quality for selectable areas of the video image. These regions give better control of the bit rate. Important parts of the scene (identified as objects in the GUI) are encoded at high resolution and therefore have an enhanced encoding quality. Less important parts (such as the sky and trees in the background, all identified as backgrounds in the GUI) are encoded at lower quality and therefore have a decreased encoding quality.

**Intelligent Defog**

Users can configure the mode to activate automatically when the global contrast enhancement method in the camera detects fog and adds light to the video image (and then deactivates when the fog clears or the scene changes).

**Advanced streaming**

The camera offers advanced streaming capabilities so that you can configure the camera to take advantage of the latest network technology. The camera is designed on an efficient and powerful H.264 encoding platform capable of delivering high-quality HD video with very low network load. The new intelligent encoding capabilities drop the bandwidth consumption to extremely low levels if the camera detects no motion in the scene. The camera is capable of quad streaming which allows the camera to be configured to deliver independent, configurable streams for live viewing, recording, or remote monitoring on over bandwidth-constrained networks.

**Recording and storage management**

A memory card (a maximum of 32 GB microSDHC / 2 TB microSDXC) can be used for local alarm recording or for scheduled local recording to improve the overall recording reliability. Recording management can be controlled by the Bosch Video Recording Manager (VRM), or the camera can use iSCSI targets directly without any recording software.

**Alarm handling and Motion Detection**

A wide range of configuration options is available for alarms signaling the camera. A built-in algorithm for detecting movement on presets can also be used for alarm signaling, or the camera can interface to an external alarm source using the built-in alarm I/O ports. In addition, a user can also schedule virtual alarms. Any of the available external alarm, motion alarm or scheduled virtual alarms can then be used to trigger a relay output or to force the camera to do certain tasks (for example, to start a guard tour or to go to a preset location).

**Access security**

Password protection with three levels and 802.1x authentication is supported. To secure Web browser access, use HTTPS with a SSL certificate stored in the

camera. The video and audio communication channels can be independently AES encrypted with 128-bit keys by installing the optional encryption site license.

#### Complete viewing software

There are many ways to access the camera's features: using a web browser, with the Bosch Video Management System, with the free-of-charge Bosch Video Client, with the Video Security App, or via third-party software.

#### Bosch Video Security app

The AUTODOME IP cameras fully support Dynamic Transcoding technology from Bosch, which – in combination with the Video Security App from Bosch – provides 24/7 remote access to camera controls, live video streams, recordings and HD images from anywhere, regardless of available bandwidth. Dynamic Transcoding automatically adjusts the bit rate to the available bandwidth to ensure smooth video streaming. When the video is paused at an incident, a full HD still image is shown instantly. To gain all benefits of Dynamic Transcoding, simply expand the IP video surveillance system with either a DIVAR IP recording solution or a VIDEOJET XTC from Bosch.

#### System integration

The camera conforms to the ONVIF Profile S specifications. This ensures interoperability between network video products regardless of manufacturer. Third-party integrators can easily access the internal feature set of the camera for integration into large projects. Visit the Bosch Integration Partner Program (IPP) website ([ipp.boschsecurity.com](http://ipp.boschsecurity.com)) for more information.

#### Ease of installation and servicing

The camera has been designed for quick and easy installation, a key feature from Bosch IP video security products.

Bosch designed the camera with the knowledge that field cables and mounts are installed before the camera is mounted. The new installation concept allows a single person to connect the cables directly to the camera without re-routing cables. The camera is easily secured to the mount with a single screw. The three-step installation process can save up to 5 minutes per camera installation compared to any conventional PTZ dome.

Indoor/outdoor pendant housings are rated to provide IP66 protection and offer an operating temperature range down to -40 °C (-40 °F). The indoor/outdoor camera comes fully assembled with a sunshield and ready for wall or pipe applications with the proper mounting hardware (sold separately). You can easily convert the outdoor pendant for indoor applications by removing the sunshield.

Bosch offers a full complement of hardware and accessories (sold separately) for wall, corner, mast, roof, pipe mount, and in-ceiling applications for indoor and outdoor environments, which allow the camera to be adapted easily to individual site requirements.

#### Dual power options

All models can be powered by a IEEE 802.3at PoE+ switch or a 24 VAC power supply. When powered using PoE+ (IEEE 802.3at class 4) configuration, only a single cable connection is required to power and to control the camera while also viewing images from the camera. For additional system reliability, users also have the option to connect the 24 VAC power supply to the camera while using PoE+.

#### Easy upgrade

Remotely upgrade the camera whenever new firmware becomes available. This ensures up-to-date products, thus protecting investment with little effort.

#### Unsurpassed reliability

As with all Bosch products, the camera is designed using the industry's best design process and is subjected to the most stringent testing standards such as HALT (highly accelerated life testing), which pushes the limits of products to ensure reliability throughout their lifetime.

### Certifications and approvals

#### HD standards

- Complies with the SMPTE 274M-2008 Standard in:
  - Resolution: 1920x1080
  - Scan: Progressive
  - Color representation: complies with ITU-R BT.709
  - Aspect ratio: 16:9
  - Frame rate: 25 and 30 frames/s
- Complies with the 296M-2001 Standard in:
  - Resolution: 1280x720
  - Scan: Progressive
  - Color representation: complies with ITU-R BT.709
  - Aspect ratio: 16:9
  - Frame rate: 25 and 30 frames/s

Marking	Applicable Standard
cULus	<ul style="list-style-type: none"> <li>• UL60950-1/-22 (ed 2) (Includes CSA 22.2 No. 60950-1/-22)</li> </ul>
FCC Part 15 (USA)	<ul style="list-style-type: none"> <li>• 47CFR Part 15</li> <li>• ICES-003 (Canada)</li> </ul>
CE (Europe)	<p><b>Electromagnetic Compatibility (EMC) Directive</b></p> <ul style="list-style-type: none"> <li>• EN 55022:2010</li> <li>• EN 50130-4:2011</li> <li>• EN 61000-3-2:2014</li> <li>• EN 61000-3-3:2013</li> </ul> <p><b>Product Safety: Low Voltage Directive</b> (IECEE CB scheme certificate and report are required)</p> <ul style="list-style-type: none"> <li>• EN 60950-1:2006+A11:2009+A1:2010 +A12:2011+A2:2013 (with national differences)</li> <li>• IEC 60950-1/-22 (ed 1)</li> </ul>
Other labels / markings	<ul style="list-style-type: none"> <li>• RCM</li> </ul>

Other requirements are defined in the *Technical specifications* section.

### Parts included

1	AUTODOME IP 5000 HD camera
1	Mounting template (in-ceiling model only)
1	Screwdriver, T15 Torx
4	MAC address labels
1	Quick Installation Guide

### Technical specifications

Full product functionality is expected for specified conditions under general requirements for the operating temperature range and power supply.

#### AUTODOME IP 5000 HD camera

Imager	1/2.8" progressive scan CMOS	
Total sensor pixels	2.48M pixels	
Effective pixels	1080p: 1984 (H) x 1105 (V) (approximately 2.43M pixels) 720p: 1344 (H) x 745 (V)	
Lens Focal Length	30x Zoom 4.3 mm–129 mm (F 1.6 - F 5.0)	
Field of View (FOV)	2.3°–65°	
Focus	Automatic with manual override	
Iris	Automatic	
Digital Zoom	16x	
<b>Sensitivity / Minimum Illumination (typical)</b>	<b>30 IRE</b>	<b>50 IRE</b>
<b>Day Mode (Color)</b>		
SensUp off	0.22 lux	0.35 lux
SensUp on (1/7.5)	0.04 lux	0.08 lux
<b>Night Mode (Black and white (monochrome))</b>		
SensUp off	0.044 lux	0.07 lux
SensUp on (1/7.5)	0.008 lux	0.016 lux
Electronic Shutter Speed	1/25 sec to 1/15,000 sec (12 steps)	
WDR	76dB (DWDR)	
Signal-to-noise Ratio (SNR)	>50dB (AGC off)	
Noise Reduction	Intelligent Dynamic Noise Reduction	

Backlight Compensation (BLC)	On/Off
Intelligent Defog	Automatically adjusts parameters for best picture in foggy or misty scenes (switchable)*
White Balance	Standard Auto, Sodium Vapor Auto, Basic Auto, Manual, Hold, Dominant Color Auto
Day/Night	Mechanical switchable IR filter (Auto/On/off) Monochrome

### Mechanical

Pan/Tilt Modes	Normal: 1°/s - 120°/s Turbo: Pan: 1°/s - 300°/s; Tilt: 1°/s - 200°/s
Preset Speed	Pan: 300°/s Tilt: 200°/s
Pan Range	360° continuous
Tilt Range	0° to ±90°
Preset Accuracy	± 0.2° typ.
Presets	256
Tours	Two (2) types of tours: <ul style="list-style-type: none"> <li>Recorded tours – two (2), maximum total duration 15 minutes (depending on the amount of commands sent during recording)</li> <li>Preset tour – one (1) consecutive, one (1) custom</li> </ul>

### Electrical

Input Voltage	24 VAC and POE+
Power Consumption	24 VAC: 14W / 24W (Heater on) POE+ : 13W (Heater not supported)

### Network

Video compression	H.264 (ISO/IEC 14496-10) M-JPEG
Streaming Capability	Quad Stream (2x H.264, 1x MJPEG, 1x i-Frame only)
Frame Rate	1080P (1 - 25/30fps) 720P (1 - 25/30fps)

When the option in field "Property" for Stream 1 is:	The available options in field "Property" for Stream 2 are:
H.264 MP SD	- H.264 MP SD
H.264 MP 720p fixed	- H.264 MP SD - H.264 MP 720p fixed - H.264 MP 400x720 upright (cropped) - H.264 MP D1 4:3 (cropped) - H.264 MP 1280x960 (cropped)*

When the option in field "Property" for Stream 1 is:	The available options in field "Property" for Stream 2 are:
H.264 MP 1080p fixed*	<ul style="list-style-type: none"> <li>- Copy Stream 1*</li> <li>- H.264 MP SD*</li> <li>- H.264 MP 720p8/10 fixed*</li> <li>- H.264 MP 1080p4/5 fixed*</li> <li>- H.264 MP 400x720 upright (cropped)*</li> <li>- H.264 MP D1 4:3 (cropped)*</li> </ul>

\* Note: This option is available for 1080p models only.

Non-recording profiles	<p>Two (2) streams, I-frame only</p> <p>Options are:</p> <ul style="list-style-type: none"> <li>- HD Image Optimized;</li> <li>- HD Balanced;</li> <li>- HD Bit Rate Optimized;</li> <li>- SD Image Optimized;</li> <li>- SD Balanced;</li> <li>- SD Bit Rate Optimized;</li> <li>- DSL Optimized;</li> <li>- 3G Optimized</li> </ul>
------------------------	---------------------------------------------------------------------------------------------------------------------------------------------------------------------------------------------------------------------------------------------------------------------------------------------------------------------------------------

Resolution	Models NEZ-5130-xxxW4	Models NEZ-5230-xxxW4
	720P (1280×720) D1 (704×576/704×480)	1080P (1920×1080) 720P (1280×720) D1 (704×576/704×480)

Ethernet	10/100BASE-T
Protocols	IPv4, IPv6, UDP, TCP, HTTP, HTTPS, RTP/RTCP, IGMP V2/V3, ICMP, ICMPv6, RTSP, FTP, Telnet, ARP, DHCP, SNMP, SNMP (V1, MIB II), 802.1x, DNS, DNSv6, DDNS (DynDNS.org, selfHOST.de, no-ip.com), SMTP, iSCSI, UPnP (SSDP), DiffServ (QoS), LLDP, SOAP, Dropbox, CHAP, digest authentication
Interoperability	ONVIF Profile S; GB/T 28181

<b>Audio</b>	
Compression	G.711, 8kHz sampling rate L16, 16kHz sampling rate AAC, 16kHz sampling rate
Interface	1/1 Channel In/Out

### Local Storage

Local storage	Memory card (a maximum of 32 GB microSDHC / 2 TB microSDXC). (An SD card of Class 6 or higher is recommended for HD recording.)
---------------	---------------------------------------------------------------------------------------------------------------------------------

### Miscellaneous

Sectors / Titling	16 independent sectors with 20 characters per title
Privacy Masking	24 individually configurable privacy masks
Video Analysis	MOTION+
Supported Languages	English, German, Spanish, French, Italian, Dutch, Polish, Portuguese, Russian, Japanese, Chinese (simplified)

### User Connections

Power, Network	RJ45 (10/100BASE-T)
Power, Camera	24 VAC
Alarm Inputs	2
Alarm Outputs	1 relay output
Audio input	1
Audio output	1

### Environmental

Ingress Protection Rating/ Standard	IP66 (pendant models) IP51 (in-ceiling model)
IK Rating	IK10 (pendant models)
Operating Temperature (Pendant models)	24 VAC: -40 °C to +60 °C (-40 °F to +140 °F) POE+ : -20 °C to +60 °C (-4 °F to +140 °F)
Operating Temperature (In-ceiling models)	-10 °C to +60 °C (+14 °F to +140 °F)
Humidity	Less than 90% RH
Storage Temperature	-40 °C to +60 °C (-40 °F to +140 °F)

### Construction

Dimensions (D x H)	Pendant models: $\Phi$ 190 mm x 303.6 mm ( $\approx$ 7.5 in. x $\approx$ 12.0 in.) With Sunshield: $\Phi$ 207 mm x 303.6 mm ( $\approx$ 8.15 in. x $\approx$ 12.0 in.) In-ceiling model: 198 mm x 176.6 mm (7.8 in. x $\approx$ 7.0 in.)
Weight	Pendant models: 2.65 kg (5.8 lb) Pendant models with sunshield: 2.72 kg (6 lb) In-ceiling model: 2.10 kg (4.6 lb)
Construction Material	Housing, Pendant models: Aluminum Housing, In-ceiling model: SPCC Sunshield: Outdoor Grade Plastic Bubble: Polycarbonate
Standard Color	White (RAL 9003)

Dimensional Drawings

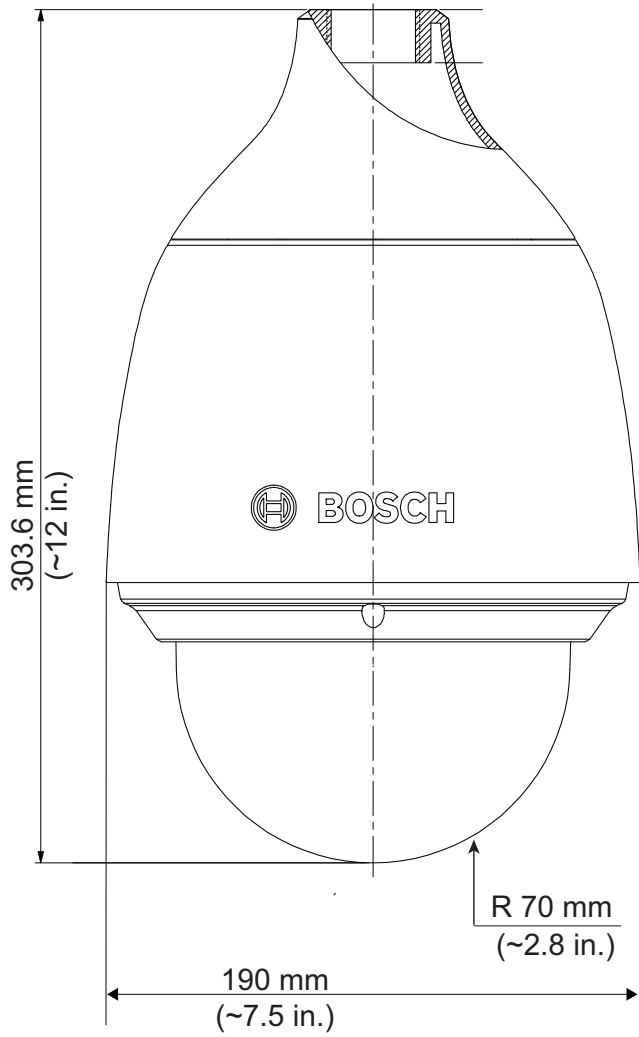

Indoor pendant

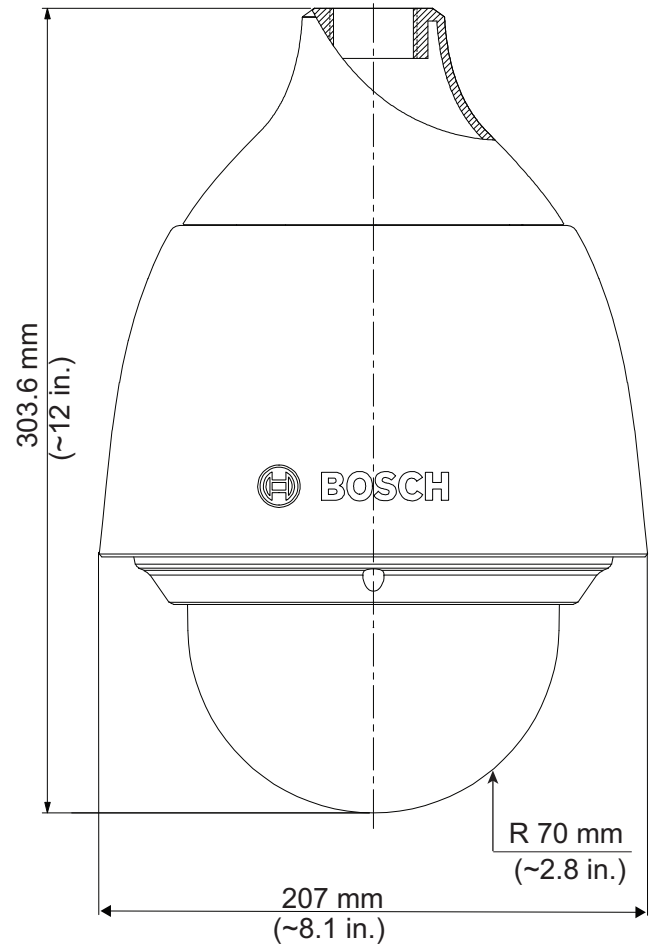

Outdoor pendant

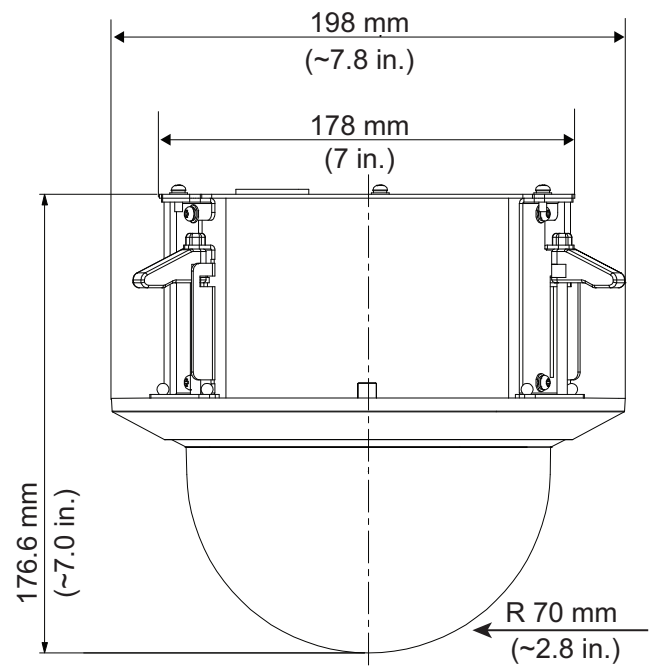

In-ceiling



**Ordering information****AUTODOME IP 5000 HD**

AUTODOME IP 5000 HD, 30x 720p30 HD camera with outdoor pendant housing and sunshield, clear bubble  
Order number **NEZ-5130-EPCW4**

**AUTODOME IP 5000 HD**

AUTODOME IP 5000 HD, 30x 1080p30 HD camera with outdoor pendant housing and sunshield, clear bubble  
Order number **NEZ-5230-EPCW4**

**AUTODOME IP 5000 HD**

AUTODOME IP 5000 HD, 30x 720p30 HD camera with indoor housing suitable for pendant installation, clear bubble  
Order number **NEZ-5130-PPCW4**

**AUTODOME IP 5000 HD**

AUTODOME IP 5000 HD, 30x 1080p30 HD camera with indoor housing suitable for pendant installation, clear bubble  
Order number **NEZ-5230-PPCW4**

**AUTODOME IP 5000 HD**

AUTODOME IP 5000 HD, 30x 1080p30 HD camera with indoor housing suitable for in-ceiling installation, clear bubble  
Order number **NEZ-5230-CPCW4**

**Accessories****NEZ-A5-BUB-CTIP**

Tinted bubble for in-ceiling housing.  
Order number **NEZ-A5-BUB-CTIP**

**NEZ-A5-BUB-PTIP**

Tinted bubble for pendant housing.  
Order number **NEZ-A5-BUB-PTIP**

**UPA-2450-50 Power Supply, 220 V, 50 Hz**

Indoor power supply for camera. 220 VAC, 50 Hz In; 24 VAC, 50 VA Out  
Order number **UPA-2450-50**

**UPA-2450-60 Power Supply, 120 V, 60 Hz**

Indoor power supply for camera. 120 VAC, 60 Hz In; 24 VAC, 50 VA Out  
Order number **UPA-2450-60**

**High PoE Midspan, 60 W, single port, AC in**

High Power, 60 W Single Port PoE Midspan with AC in  
Order number **NPD-6001A**

**VEZ-A5-WMB Wall Mount Bracket**

Mount for installing an AUTODOME 5000 camera on a wall  
Order number **VEZ-A5-WMB**

**VEZ-A5-PP AUTODOME 5000 Pipe Mount**

Mount for installing an AUTODOME 5000 camera onto a pipe.  
Order number **VEZ-A5-PP**

**VDA-A-JNB Junction Box without power supply**

Junction Box without power supply for dome cameras.  
Order number **VDA-A-JNB**

**VG4-A-9541 Pole Mount Adapter**

Pole mount adapter for a VDA-A-JNB Junction box for outdoor applications.  
Order number **VG4-A-9541**

**VDA-POMT-PTZDOME Pole Mount Adapter**

Pole mount adapter for indoor application  
Order number **VDA-POMT-PTZDOME**

**VG4-A-9542 Corner Mount Adapter**

Corner mount adapter for VDA-A-JNB Junction Box for outdoor applications  
Order number **VG4-A-9542**

**VDA-CMT-PTZDOME Corner Mount Adapter**

Corner mount adapter for indoor application  
Order number **VDA-CMT-PTZDOME**

**VGA-IC-SP In-ceiling Support Kit**

Suspended ceiling support kit for FLEXIDOME cameras (requires VDA-PLN-DOME kit).  
Order number **VGA-IC-SP**

**Represented by:****Americas:**

Bosch Security Systems, Inc.  
130 Perinton Parkway  
Fairport, New York, 14450, USA  
Phone: +1 800 289 0096  
Fax: +1 585 223 9180  
security.sales@us.bosch.com  
www.boschsecurity.us

**Europe, Middle East, Africa:**

Bosch Security Systems B.V.  
P.O. Box 80002  
5617 BA Eindhoven, The Netherlands  
Phone: +31 40 2577 284  
Fax: +31 40 2577 330  
emea.securitysystems@bosch.com  
www.boschsecurity.com

**Asia-Pacific:**

Robert Bosch (SEA) Pte Ltd, Security Systems  
11 Bishan Street 21  
Singapore 573943  
Phone: +65 6571 2808  
Fax: +65 6571 2699  
apr.securitysystems@bosch.com  
www.boschsecurity.asia

**China:**

Bosch (Shanghai) Security Systems Ltd.  
203 Building, No. 333 Fuquan Road  
North IBP  
Changning District, Shanghai  
200335 China  
Phone +86 21 22181111  
Fax: +86 21 22182398  
www.boschsecurity.com.cn

**America Latina:**

Robert Bosch Ltda Security Systems Division  
Via Anhanguera, Km 98  
CEP 13065-900  
Campinas, Sao Paulo, Brazil  
Phone: +55 19 2103 2860  
Fax: +55 19 2103 2862  
latam.boschsecurity@bosch.com  
www.boschsecurity.com