

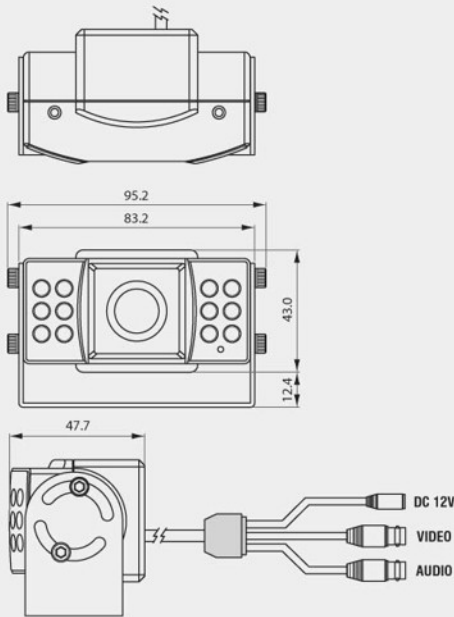

Features

- 1/3 inch IT CCD
- Normal Resolution : 420 TV Lines
- Built in Fixed Lens (f=2.5mm)
- Built-in IR LED(12ea)
- **Intelligent IR Technology**
- Min. Illumination : 0.00 Lux (IR LED On)
- Auto White Balance
- Audio & Mirror Function

DIMENSIONS



SPECIFICATIONS

Model	LML-10S	LML-11S
Signal System	NTSC	PAL
Scanning System	2:1 Interlace	
Scanning Frequency (H)	15.734 KHz	15.625 KHz
Scanning Frequency (V)	59.94 Hz	50 Hz
Image Sensor	1/3 Inch IT CCD	
Total Pixels	537 (H) x 505 (V) 270K	537 (H) x 597(V) 320K
Total / Effective Pixels	510 (H) x 492 (V) 250K	500 (H) x 582 (V) 290K
Horizontal Resolution	420 TV Lines	
Video Output	1.0V p-p (75Ω, Composite)	
Audio Output	2V p-p	
S/N Ratio	More than 50dB (AGC Off)	
Lens	Built-in Fixed Lens (f=2.5mm)	
Min.Illumination	Intelligent IR Technology. Day (0.05 Lux), Night (0.00 Lux, IR LED On)	
IR LED and Sensor	IR LED (850nm, 30°) 12EA	
IR LED Visible Range	Max. 10m	
White Balance	Auto	
AGC	Auto	
Shutter Speed	1/60~1/120,000 Sec.	1/50~1/120,000sec.
Supplied Voltage	DC10V~14V (Recommendation DC12V±0.5V)	
Power Consumption	Max. 2W	
Dimensions (WxHxD)	83.2 x 43.0 x 47.7 mm	