

Sarix® TI Series Thermal IP Positioning Systems

IP AND ANALOG THERMAL CAMERA WITH INTEGRATED ESPRIT® PAN/TILT

Product Features

- Uncooled, Sun-Safe, Amorphous Silicon Microbolometer
- Long Wave Infrared (LWIR)
- Esprit® Pan/Tilt
- IP and Analog Capability
- 640 x 480 and 384 x 288 Resolution Options
- 17 µm Pixel Size (640 x 480 model)
- 25 µm Pixel Size (384 x 288 model)
- Sensitivity Below NETD <50 mK at f/1.0
- 24 VAC or 120/230 VAC 50/60 Hz Selectable
- H.264 and MJPEG Compression
- Ability to Control and Monitor Video Over IPv4 and IPv6 Networks
- Built-in Analytics
- Variable Speed Pan, 0.1° to 100°/Sec with Proportional Pan
- 360° Continuous Pan Rotation
- Tilt Range of +33° to –83° from Horizontal

Positioning System

The **Sarix® TI Series Thermal IP Positioning System** is an advanced thermal imaging pan/tilt system designed for easy integration into any new or existing video security application. The system is designed to provide detection, recognition, and identification of people and vehicles in any lighting condition, including complete darkness. Every **Sarix TI Series** features IP or analog outputs in the same package and an integrated environmentally protected IP66 rated enclosure with Esprit® pan/tilt positioner, which can be controlled using IP or analog systems that use Coaxitron® or RS-422 Pelco D and Pelco P protocols. Additionally, when used in an IP system, the **Sarix TI Series** features a full suite of designed-for-thermal analytics.

At the core of the **Sarix TI Series** is an uncooled, sun-safe microbolometer, long-wavelength infrared (LWIR) camera that delivers up to 640 x 480 thermal video. These cameras feature an amorphous silicon detector, which has lower fixed pattern noise and a more uniform response than vanadium oxide detectors, while still maintaining high resolution and sensitivity when exposed directly to the sun during normal daylight hours.

The **Sarix TI Series** provides outstanding sensitivity below 50 mK at f/1.0. It is capable of multiple display formats, including white hot, black hot, and color signatures. The **Sarix TI Series** is available with multiple lens configurations for effective deployment in a wide range of applications.



- Preset Positioning, Patterns, and Multiple Scan Modes
- Designed for Minimal Maintenance, No Gears to Adjust
- Adaptive Motion Detection
- ONVIF v1.02 Conformant

The **Sarix TI Series** is available in 640 x 480 and 384 x 288 resolution options. The camera has an input voltage of 24 VAC or a selectable power source of 120/230 VAC.

In IP installations, the **Sarix TI Series** can support two simultaneous video streams. The two streams can be compressed in MJPEG and H.264 formats across several resolution configurations. The streams can be configured to a variety of frame rates, bit rates, and group of pictures (GOP) structures for additional bandwidth administration. When used in analog installations, the **Sarix TI Series** supports camera control and limited camera setup using Coaxitron®, Pelco P, and Pelco D protocols.

The **Sarix TI Series** provides variable pan and tilt speeds ranging from 0.1 to 40 degrees per second in manual pan mode and 0.1 to 20 degrees per second in manual tilt mode. Pan preset and turbo speeds are 100 degrees per second in wind speeds of 50 mph and 50 degrees per second in the 90 mph wind-speed profile. Tilt preset speed is 30 degrees per second. The **Sarix TI Series** is capable of 360 degrees of continuous pan rotation. The tilt range allows for horizontal viewing of +33 to –83 degrees. Preset positions have a preset accuracy of one-quarter degree.

The powder-coated aluminum enclosure makes the **Sarix TI Series** ideal for either indoor or outdoor applications. The system has a sustained operating temperature range of –40° to 50°C (–40° to 122°F). A built-in heater/defroster and sun shroud are standard features on the **Sarix TI Series**.



by Schneider Electric

International Standards
Organization Registered Firm;
ISO 9001 Quality System



C1317 / REVISED 8-20-14

TECHNICAL SPECIFICATIONS

PELCO ANALYTICS

Pelco™ Analytics enhance the flexibility and performance of the Sarix TI Series when used in an IP video system. Pelco Analytics are easy to configure for alarm notification when used with Endura® or a third-party system that supports Pelco's Analytics API system.

The Sarix TI Series includes five user-configurable behaviors. The camera is capable of running up to three behaviors simultaneously.

Note: For each behavior, you can create several custom profiles that contain different camera settings. With these profiles, you can set up different scenarios for the behavior, which will automatically detect and trigger alarms when specific activity is detected.

Pelco Analytics are configured and enabled using a standard Web browser, and Pelco behavior alarms are compatible with Endura or a third-party system that supports Pelco's API system. Multiple Pelco analytics can be scheduled to work during a certain time or condition. For example, during the day, a camera can be configured with Object Counting to count the number of people that enter a lobby door. At night, the operator can change the profile to Camera Sabotage to trigger an alarm if a camera is moved or obstructed. Each suite includes the following behaviors:

- **Adaptive Motion Detection:** Detects and tracks objects that enter a scene and then triggers an alarm when the objects enter a user-defined zone or cross a trip wire. This behavior is primarily used in outdoor environments with light traffic to reduce the number of false alarms caused by environmental changes.
- **Camera Sabotage:** Detects contrast changes in the field of view. An alarm is triggered if the lens is obstructed with spray paint, a cloth, or covered with a lens cap. Any unauthorized repositioning of the camera also triggers an alarm.
- **Loitering Detection:** Identifies when people or vehicles remain in a defined zone longer than the user-defined time allows. This behavior is effective in real-time notification of suspicious behavior around ATMs, stairwells, and school grounds.
- **Object Counting:** Counts the number of objects that enter a defined zone or cross a trip wire. This behavior might be used to count the number of people at a store entrance/exit or inside a store where the traffic is light. This behavior is based on tracking and does not count people in a crowded setting.
- **Stopped Vehicle:** Detects vehicles stopped near a sensitive area longer than the user-defined time allows. This behavior is ideal for airport curbside drop-offs, parking enforcement, suspicious parking, traffic lane breakdowns, and vehicles waiting at gates.

WEB INTERFACE

The Sarix TI Series uses a standard Web browser for powerful remote setup and administration.

ADDITIONAL PRODUCT FEATURES

- Operational in 145 km/h (90 mph) Winds, Can Withstand Wind Velocity up to 209 km/h (130 mph)
- Pan Preset Speed of 100°/Sec in 80 km/h (50 mph) Winds and 50°/Sec in 145 km/h (90 mph) Winds
- Variable Scan Speeds (1 to 40°/Sec)
- Multiple Lens Options
- Designed for Maximum Environmental Protection
- Compact, Lightweight Aluminum Construction
- Meets NEMA Type 4X and IP66 Standards
- Complete with Sun Shroud and Heater/Defroster
- Analog Control using Coaxitron, Pelco P, or Pelco D Protocols

THERMAL CAMERA/OPTICS

Detector	Uncooled, sun-safe, amorphous silicon microbolometer
Array Format	640 x 480 or 384 x 288
Pixel Size	
640 x 480	17 µm
384 x 288	25 µm
Effective Resolution	307,200 (640 x 480); 110,592 (384 x 288)
Spectral Response	7.5 to 13.5 µm, LWIR
Normalization Source	Internal shutter (offset only), 0.3 second video freeze during shutter
Temporal NETD	50 mK at f/1.0
Front Window	Germanium with Diamond-Like Coating (DLC) with resistance to abrasion, salts, acids, alkalis, and oil
Display Formats	White hot, black hot, and rainbow

LENS

640 x 480			
Lens (mm)	F-Number (f)	Field of View (H/V/D)	Near Focus Distance
35	1.4	18° x 13° x 22°	13.0 m (42.6 ft)
50	1.2	12° x 9° x 15°	22.0 m (72.2 ft)
100	1.6	6° x 5° x 8°	92.0 m (301.8 ft)
384 x 288			
14.25	1.2	39° x 29° x 48°	1.6 m (5.2 ft)
35	1.4	16° x 12° x 19°	8.8 m (28.8 ft)
50	1.7	11° x 8° x 14°	15.0 m (49.2 ft)
100	1.6	6° x 4° x 7°	63.0 m (206.6 ft)

TECHNICAL SPECIFICATIONS

VIDEO

IP/NETWORK

Video Encoding	H.264 High, Main, or Base profiles; MJPEG, and JPEG
Video Streams	Up to 2 simultaneous streams; the second stream is variable based on the setup of the primary stream
Frame Rate	Up to 30, 25, 24, 15, 12.5, 12, 10, 8, 7.5, 6, 5, 4, 3, 2.5, 2, 1 (dependent upon stream configuration)

Available Resolutions

Resolution			JPEG		H.264 High Profile	
Width	Height	Aspect Ratio	Maximum IPS*	Recommended Bit Rate (Mbps)	Maximum IPS*	Recommended Bit Rate (Mbps)
640 x 480 Resolution						
640	480	4:3	30	4.79	30	1.41
320	240	4:3	30	1.17	30	0.49
384 x 288 Resolution						
384	288	4:3	30	1.71	30	0.63
320	240	4:3	30	1.17	30	0.49
320	176	16:9	30	0.88	30	0.34

*Models with a "-X" suffix part number have a maximum images per second (ips) of 25. Models with a "-X1" suffix part number have a maximum ips of 8.3.

Supported Protocols	TCP/IP, UDP/IP (Unicast, Multicast IGMP), UPnP, DNS, DHCP, RTP, RTSP, NTP, IPv4, IPv6†, SNMP, QoS, HTTP, HTTPS, LDAP (client), SSH, SSL, SMTP, FTP, and 802.1x (EAP)
Users	
Unicast	Up to 20 simultaneous users depending on resolution settings (2 guaranteed streams)
Multicast	Unlimited users H.264
Security Access	Password protected
Software Interface	Web browser view and setup
Pelco System Integration	Endura 2.0 (or later) Digital Sentry® 7.3 (or later)
Open API	Pelco API or ONVIF v1.02

ANALOG

Video/Coaxitron Port	75 ohms, unbalanced
Video Modes	NTSC or PAL
Video Level	1 Vp-p

† Supports mixed IPv4 and IPv6 environments, but not IPv6-only deployments.

MECHANICAL

Pan Movement	360° continuous pan rotation	
Vertical Tilt	33° to -79° unobstructed from horizontal	
Variable Pan/Tilt Speed	<u>Analog Control</u>	<u>IP Control</u>
Pan	0.5° to 40°/sec 100°/sec turbo	0.1° to 100°/sec
Tilt	0.5° to 20°/sec	0.1° to 30°/sec
Preset Speeds		
Pan	100° per second	
Tilt	30° per second	
Latching	2 captive Torx™ screws	

†Assumes maximum operating capacity.

ELECTRICAL

Ethernet Port	Inline RJ-45 for 100Base-TX, auto MDI/MDI-X		
Ethernet Cabling Required	Cat5 or better for 100Base-TX		
Input Power	24/120/230 VAC, 50/60 Hz, switch selectable for 120/230 VAC		
Input Power Range	+15%/-20%		
Power Consumption	<u>Lens</u>	<u>Power</u>	
24 VAC	14.25, 35, 50 mm	3.87 A, 102.2 VA (100 W)	
115 VAC	100 mm	6.12 A, 161.6 VA (160 W)	
230 VAC	14.25, 35, 50 mm	0.83 A, 109.4 VA (105 W)	
	100 mm	1.30 A, 171.6 VA (170 W)	
	14.25, 35, 50 mm	0.41 A, 109.4 VA (105 W)	
	100 mm	0.65 A, 172.4 VA (170 W)	
24 VAC Fuse	8.0 A, slow-blow		
120/230 VAC Fuse	2 A, slow-blow		
Heater	Thermostat controlled		
Local Storage	Micro SD		
Alarm Inputs	N.O. switch, N.C. switch, or 1 kohm; supervised		
Mechanical Relay Output†	<u>Voltage</u>	<u>Current</u>	<u>Power</u>
	60 VDC, 125 VAC	1 A	62.5 VA, 30 W
Solid-State Relay Output†	32 V	100 mA	(N/A)
Audio			
Input	UTP 600 ohm mono, 12 VDC power source, line level/external microphone input, 1 Vp-p maximum signal level		
Compression	G.711 PCM, 64 kbps		
Serial Control Port	4-wire, RS-422/RS-485 (Pelco D or Pelco P)		
Serial Control Cabling Type	UTP		

GENERAL

Construction	Aluminum	
Finish	Gray polyester powder coat	
Environment	Indoor/outdoor	
Operating Temperature	-40° to 50°C (-40° to 122°F)	
Storage Temperature	-40° to 60°C (-40° to 140°F)	
Weight	<u>Unit</u>	<u>Shipping</u>
	ESTI314-2N/5N	11.2 kg (24.6 lb) 15 kg (33 lb)
	ESTI314-2W/5W	11.8 kg (26.1 lb) 16 kg (34 lb)
	ESTI335-2N/5N	11.3 kg (24.9 lb) 15 kg (33 lb)
	ESTI335-2W/5W	12.0 kg (26.4 lb) 16 kg (35 lb)
	ESTI350-2N/5N	11.3 kg (25.0 lb) 15 kg (33 lb)
	ESTI350-2W/5W	12.0 kg (26.5 lb) 16 kg (35 lb)
	ESTI3100-2N/5N	11.4 kg (25.2 lb) 15 kg (33 lb)
	ESTI3100-2W/5W	12.1 kg (26.7 lb) 16 kg (35 lb)
	ESTI635-2N/5N	11.3 kg (24.9 lb) 15 kg (33 lb)
	ESTI635-2W/5W	12.0 kg (26.4 lb) 16 kg (35 lb)
	ESTI650-2N/5N	11.3 kg (25.0 lb) 15 kg (33 lb)
	ESTI650-2W/5W	12.0 kg (26.5 lb) 16 kg (35 lb)
	ESTI6100-2N/5N	11.4 kg (25.2 lb) 15 kg (33 lb)
	ESTI6100-2W/5W	12.1 kg (26.7 lb) 16 kg (35 lb)

CERTIFICATIONS/RATINGS/PATENTS

- CE, Class A
- FCC, Class A
- UL/cUL Listed
- C-Tick
- Meets NEMA Type 4X and IP66 standards
- Shock and Vibration, Meets NEMA TS 2; IEC613736-8, -9, -10
- Cisco® Medianet (MSP) Compatible
- ONVIF v1.02

TECHNICAL SPECIFICATIONS

 NOTE: VALUES IN PARENTHESES ARE INCHES; ALL OTHERS ARE CENTIMETERS.

PEDESTAL MOUNT MODELS

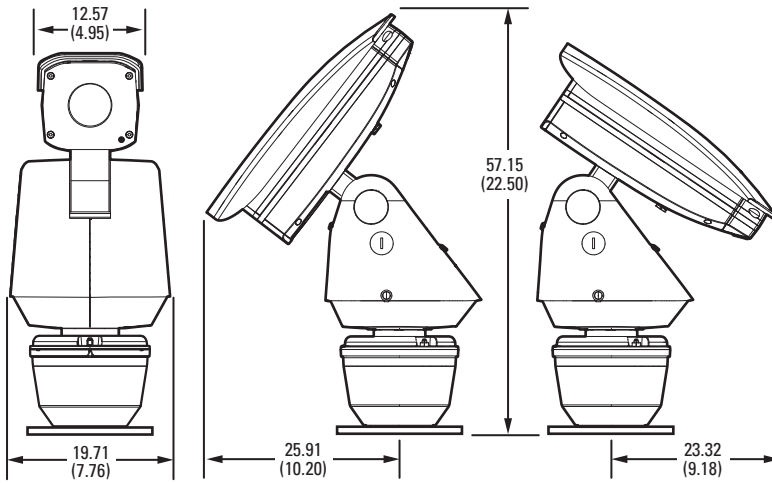

WALL MOUNT MODELS

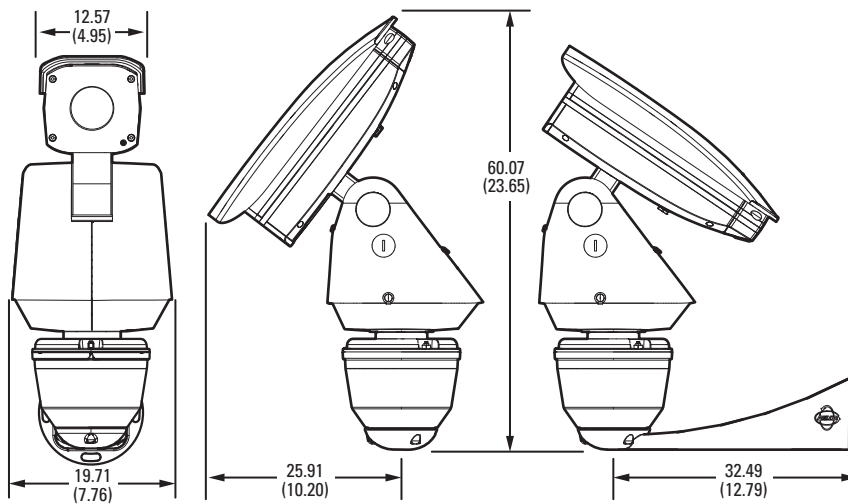

PEDESTAL MOUNTING PATTERN

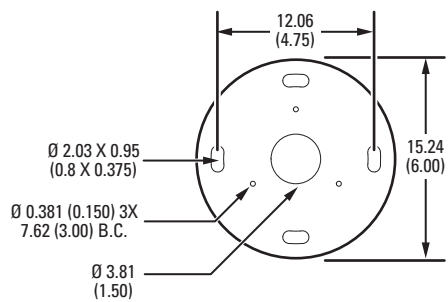

WALL MOUNTING PATTERN

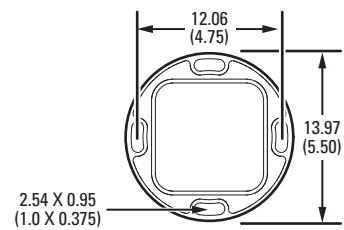

TECHNICAL SPECIFICATIONS

RANGE PERFORMANCE*

640 x 480

Detection, Recognition, and Identification of a Human Target

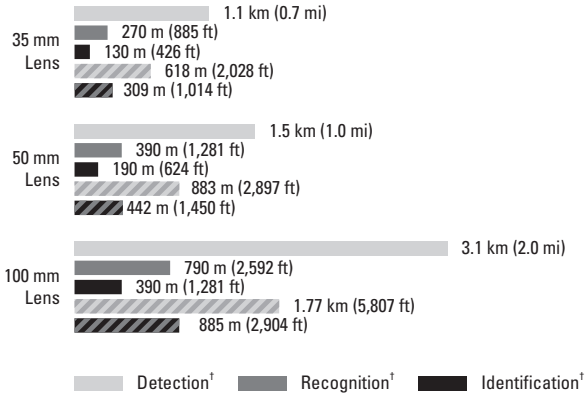

Detection, Recognition, and Identification of a Vehicle Target

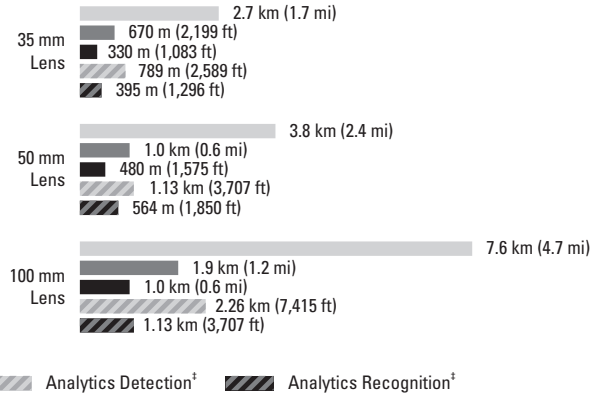

384 x 288

Detection, Recognition, and Identification of a Human Target

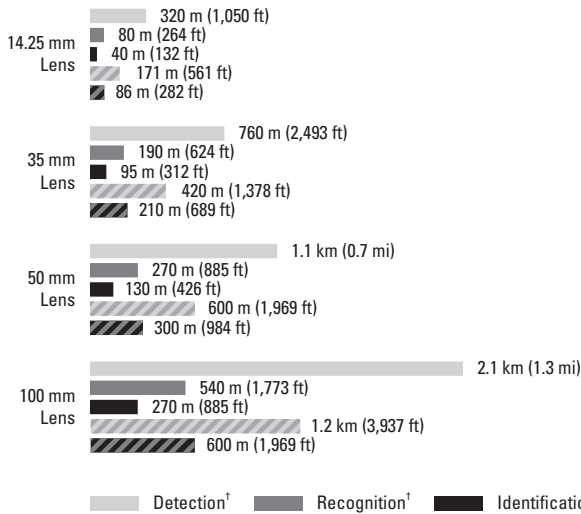

Detection, Recognition, and Identification of a Vehicle Target

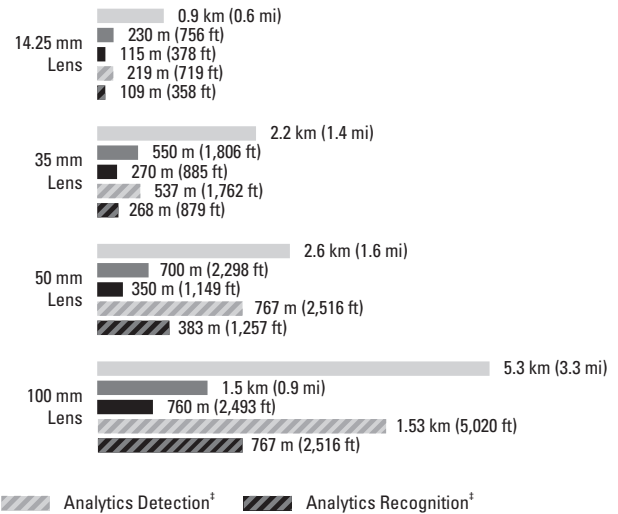

*Range performance can vary based on camera setup, user experience, environmental conditions, and display type used. Calculations are based on 2°C (36°F) difference, 50 percent probability of target detection, and 0.85/km atmospheric attenuation factor.

[†]The number of pixels on target are assumed to be 1.5 pixels for detection, 6 pixels for recognition, and 12 pixels for identification; the size of a human target is assumed to be 1.8 m (5.9 ft) vertical and 0.5 m (1.6 ft) horizontal; the size of a vehicle target is assumed to be 2.3 m (7.6 ft) vertical and 2.3 m (7.6 ft) horizontal.

[‡]User-configured analytics will trigger an alarm at the full analytics detection range; however, analytics will only classify objects at the analytics recognition range. Because a vehicle is larger than a human, the vehicle analytics detection and recognition ranges can be larger than the human ranges as described below:

Range	Human Analytics	Vehicle Analytics
Detection	1.8 m/6 pixels	2.3 m/6 pixels
Recognition	1.8 m/12 pixels	2.3 m/12 pixels

TECHNICAL SPECIFICATIONS

MODELS*

640 x 480

Lens	Format	Pedestal Mount†		Wall Mount‡	
		24 VAC	120/230 VAC	24 VAC	120/230 VAC
35 mm	NTSC	ESTI635-2N	ESTI635-5N	ESTI635-2W	ESTI635-5W
	PAL	ESTI635-2N-X	ESTI635-5N-X	ESTI635-2W-X	ESTI635-5W-X
	PAL, 8.33 ips	ESTI635-2N-X1	ESTI635-5N-X1	ESTI635-2W-X1	ESTI635-5W-X1
50 mm	NTSC	ESTI650-2N	ESTI650-5N	ESTI650-2W	ESTI650-5W
	PAL	ESTI650-2N-X	ESTI650-5N-X	ESTI650-2W-X	ESTI650-5W-X
	PAL, 8.33 ips	ESTI650-2N-X1	ESTI650-5N-X1	ESTI650-2W-X1	ESTI650-5W-X1
100 mm	NTSC	ESTI6100-2N	ESTI6100-5N	ESTI6100-2W	ESTI6100-5W
	PAL	ESTI6100-2N-X	ESTI6100-5N-X	ESTI6100-2W-X	ESTI6100-5W-X
	PAL, 8.33 ips	ESTI6100-2N-X1	ESTI6100-5N-X1	ESTI6100-2W-X1	ESTI6100-5W-X1

384 x 288

Lens	Format	Pedestal Mount†		Wall Mount‡	
		24 VAC	120/230 VAC	24 VAC	120/230 VAC
14.25 mm	NTSC	ESTI314-2N	ESTI314-5N	ESTI314-2W	ESTI314-5W
	PAL	ESTI314-2N-X	ESTI314-5N-X	ESTI314-2W-X	ESTI314-5W-X
	PAL, 8.33 ips	ESTI314-2N-X1	ESTI314-5N-X1	ESTI314-2W-X1	ESTI314-5W-X1
35 mm	NTSC	ESTI335-2N	ESTI335-5N	ESTI335-2W	ESTI335-5W
	PAL	ESTI335-2N-X	ESTI335-5N-X	ESTI335-2W-X	ESTI335-5W-X
	PAL, 8.33 ips	ESTI335-2N-X1	ESTI335-5N-X1	ESTI335-2W-X1	ESTI335-5W-X1
50 mm	NTSC	ESTI350-2N	ESTI350-5N	ESTI350-2W	ESTI350-5W
	PAL	ESTI350-2N-X	ESTI350-5N-X	ESTI350-2W-X	ESTI350-5W-X
	PAL, 8.33 ips	ESTI350-2N-X1	ESTI350-5N-X1	ESTI350-2W-X1	ESTI350-5W-X1
100 mm	NTSC	ESTI3100-2N	ESTI3100-5N	EST3100-2W	ESTI3100-5W
	PAL	ESTI3100-2N-X	ESTI3100-5N-X	ESTI3100-2W-X	ESTI3100-5W-X
	PAL, 8.33 ips	ESTI3100-2N-X1	ESTI3100-5N-X1	ESTI3100-2W-X1	ESTI3100-5W-X1

*Some models may be subject to US government export control regulations.

† Pedestal mount models include Esprit EPP pedestal adapter plate. Use with PM2000/PM2010 mount (not supplied) for pedestal application.

‡ Wall mount models include Esprit EWM wall mount. Optional mounting adapters for corner, pole, and parapet applications are available.

RECOMMENDED MOUNTS AND ADAPTERS

ECM100	Corner mount adapter; for use with EWM wall mount
EPM	Pole mount adapter; for use with EWM wall mount
EA4348	Parapet mount adapter; for use with EWM wall mount
PM2000/PM2010	Pedestal mount with cable feedthrough; for use with Esprit systems with EPP pedestal adapter plate
PP4348	Rooftop parapet mount; use with EA4348 adapter

RECOMMENDED POWER SUPPLIES

MCS Series	Multiple 24 VAC camera power supply, indoor
WCS Series	Single/multiple 24 VAC camera power supply, outdoor

OPTIONAL ACCESSORIES

SECURE-SLA License	Enables Information Assurance compliant mode of operation
--------------------	---

Pelco by Schneider Electric

3500 Pelco Way, Clovis, California 93612-5699 United States

USA & Canada Tel (800) 289-9100 Fax (800) 289-9150

International Tel +1 (559) 292-1981 Fax +1 (559) 348-1120

www.pelco.com www.pelco.com/community

Pelco, the Pelco logo, and other trademarks associated with Pelco products referred to in this publication are trademarks of Pelco, Inc. or its affiliates. ONVIF and the ONVIF logo are trademarks of ONVIF Inc. All other product names and services are the property of their respective companies.

Product specifications and availability are subject to change without notice.
©Copyright 2014, Pelco, Inc. All rights reserved.