

1.3MP Vandal-resistant Network IR Fixed Dome Camera

IPC321SR3-VSPF28 (40)(60)



Key Features

Optics

- Day/night functionality
- SmartIR, up to 30 m (98 ft) IR distance
- 3D DNR (Digital Noise Reduction)

Compression

- Triple streams
- ROI (Region of Interest)
- 9:16 corridor format
- Customized OSD

Network

- ONVIF Conformance

Structure

- Wide temperature range: -35°C to 60°C (-31°F to 140°F)
- Wide input voltage range of $\pm 25\%$
- IK10 vandal resistant
- IP67

Specifications

	IPC321SR3-VSPF28	IPC321SR3-VSPF40	IPC321SR3-VSPF60
Camera			
Sensor	1/3", 1.3 megapixel, progressive scan CMOS		
Lens	2.8 mm@F2.1	4.0 mm@F2.1	6.0 mm@F2.1
Angle of View(H)	105.2°	76.6°	51.5°
Shutter	Auto/Manual, 1/6~1/100000 s		
Min. Illumination	Colour: 0.02 Lux (F2.1, AGC ON) 0 Lux with IR		
Day/Night	IR-cut filter with auto switch (ICR)		
S/N	>50 dB		
WDR	Supported		
Video			
Max. Resolution	1280 × 960		
Video Compression	H.264,MJPEG		
Frame Rate	960P (1280*960): Max. 30 fps; 720P (1280*720): Max. 10 fps; 960P (1280*960): Max. 25 fps; 720P (1280*720): Max. 15 fps; D1 (720*576): Max. 6 fps		
Video Streaming	Triple		
9:16 Corridor Mode	Supported		
ROI	Supported		
Evaluative Metering	Supported		
OSD	Up to 8 OSDs		
Privacy Mask	Up to 4 areas		
Storage			
Edge Storage	Micro SD, up to 128 GB		
Network			
Protocols	L2TP,IPv4,IGMP,ICMP,ARP,TCP,UDP,DHCP,PPPoE,RTP,RTSP,NTP,FTP,HTTP		
Compatible Integration	ONVIF,API		
Interface			
Network	10M/100M Base-TX Ethernet		
General			
Power	12 V DC, or PoE (IEEE802.3 af)		
	Power consumption: Max 5.5W		
Dimensions (Ø x H)	Ø108.5 x 81 mm (Ø4.28" x 3.2")		
Weight	0.45 kg (0.99 lb)		
Working Environment	-35°C ~ +60°C (-31°F ~ 140°F), Humidity ≤ 90% RH(non-condensing)		
Ingress Protection	IP67		
Vandal Resistant	IK10		

Dimensions

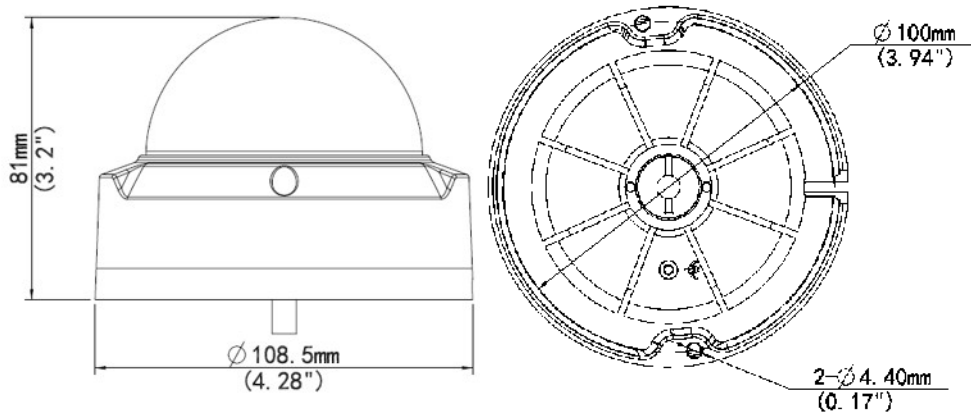

Installation

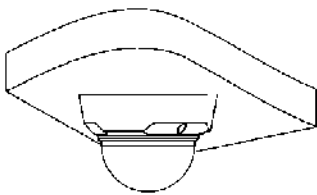

Ceiling mount

Accessories

Installation mode	Accessories	Description
Ceiling mount	Mounting pedestal is included in the Product package	\

Zhejiang Uniview Technologies Co., Ltd.

South Tower, Building 10, Wanlun Science Park, 88 Jiangling Road, Hangzhou, P.R.China 310051

Email: overseasbusiness@uniview.com; globalsupport@uniview.com

<http://www.uniview.com>

©2016-2017 Zhejiang Uniview Technologies Co., Ltd. All rights reserved.

*Product specifications and availability are subject to change without notice.