

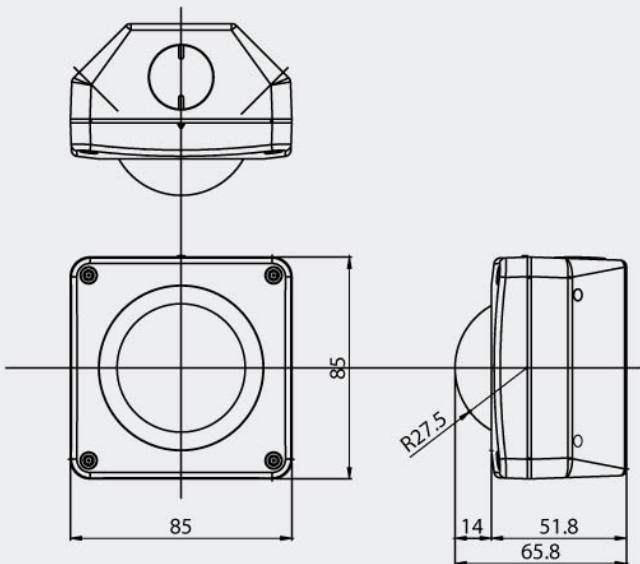

Features

- 1/3 inch Sony Super HAD CCD
- High Resolution : 530 TV Lines
- Built-in Fixed Lens (f=3.8mm)
- Min. Illumination : 0.3 Lux
- Auto White Balance (AWB)
- Auto Gain Control (AGC)
- Dome Size 55mm
- Vandal-Resistant Housing
- 12VDC

DIMENSIONS



SPECIFICATIONS

Model	VC1760N	VC1760P
Signal System	NTSC	PAL
Scanning System	2:1 Interlace	
Scanning Frequency (H)	15.734 KHz	15.625 KHz
Scanning Frequency (V)	59.94 Hz	50 Hz
Image Sensor	1/3 Inch SONY Super HAD CCD	
Total Pixels	811(H) x 508(V) 410K	795(H) x 596(V) 470K
Total / Effective Pixels	768(H) x 494(V) 380K	752(H) x 582(V) 440K
Horizontal Resolution	530 TV Lines	
Video Output	1.0V p-p (75Ω, Composite)	
S/N Ratio	More than 48dB(AGC Off)	
Lens	Fixed Lens (f=3.8mm)	
Min.Illumination	0.3 Lux	
White Balance	Auto	
AGC,BLC,Flickerless	On/Off (Dip Switch)	
Shutter Speed	1/60~1/100,000 Sec.	1/50~1/100,000 sec.
Supplied Voltage	DC 12V (10V~15V)	
Dimensions(ØxWxH)	55 x 85 x 85	