

## CAIPBC210T

[www.black.honeywell.com](http://www.black.honeywell.com)

### High Definition 720P H.264 IP Box Camera

Honeywell Black™ IP camera CAIPBC210T is a superior 720P IP camera designed for advanced security applications that require ultra high image quality at minimal costs.

The CAIPBC210T delivers high definition images in 720P (1280 x 720) resolution. The camera is equipped with True Day/Night with a mechanical IR-cut filter which guarantees superior image quality at both day and night time.

By applying the H.264 video compression technology, the CAIPBC210T streams high quality images at optimized bandwidth to reduce data volume effectively to save storage space. It also supports the ONVIF specification for high interoperability between network video products.

Power over Ethernet (PoE) option is available (CAIPBC210T-P). Power can be supplied via the network by using the standard Ethernet cable. It increases installation flexibility, reduces installation time and costs, and eliminates the need for complicated wiring.

The CAIPBC210T is compatible with Honeywell Black™'s CMS integrated network surveillance solution CAIPC-CMS100 which effectively controls video management, user management, storage, streaming data transmission, video output etc to develop a high performance system.

#### Market Opportunities

Featuring 720P resolution, H.264 video compression, PoE and ONVIF interface, the CAIPBC210T / CAIPBC210T-P IP cameras optimize performance for applications that require excellent image clarity and high-definition imaging at minimal bandwidth. Also with quick installation and True Day/Night features, these IP cameras provide optimum performance for medium-scale indoor and outdoor applications.

#### FEATURES

- 720P high definition resolution
- High-profile H.264 Compression format, support multiple video stream simultaneously
- True Day/Night – IR-CUT removable
- Motion detection, Privacy Masking, Reset
- Alarm I/O, RS485 interface
- Support local storage for SD card
- Local analog output for easy setup
- 12 VDC/24 VAC or PoE (CAIPBC210T-P only)
- ONVIF compliant



*(lens excluded)*



Driving IP-based physical security through global standardization

## CAIPBC210T

www.black.honeywell.com

### High Definition 720P H.264 IP Box Camera

#### SPECIFICATIONS

Model	CAIPBC210T	CAIPBC210T-P
Operation		
Image Sensor	2 Megapixel, 1/3" Progressive Scan CMOS sensor	
Effective Pixels	1600 (H) x 1200 (V)	
Minimum Illumination	Color: 0.5 Lux @ F1.2, AGC ON; B/W: 0.08 Lux @ F1.2, AGC ON	
Day/Night	TDN , IR cut removable	
Lens	DC Iris, Manual Iris	
Shutter Speed	1/25 - 1/10,000 Sec	
Digital Noise Reduction	ON/OFF	
Sync System	Internal	
Auto Gain Control	ON/OFF	
White Balance	ATW	
BLC	ON/OFF	
Image Set	Saturation, Brightness, Sharpness and Contrast setup is quick an easy and can be customized through a web client or IE Browser	
OSD Overlay	Name / date / stream information; position adjustable	
IP Specification		
Video Compression	H.264, MJPEG, Multiple video streams	
Image Resolution	1280 x 720 @ 25/30fps	
Bit Rate	32K - 8Mbps	
Network Interface Protocol	Support ONVIF 1.02	
Ethernet	10/100Mbps self-adaptive Ethernet interface	
Supported Protocol	TCP/IP, UDP, RTP/RTCP, RTSP, HTTP, SMTP, DNS, DDNS, DHCP, FTP, NTP, PPPOE, UPNP (SNMP, HTTPS, SIP optional)	
Audio Compression	G.711	
Audio Compression Rate	64Kbps	
Audio Input	Mic/Line in, bi-directional audio, frequency responsibility: 50 - 16000Hz, S/N>60dB	
Audio Output	Line out PWL Resistance: 600Ohm	
Local Storage	SD card	
SD card Storage	Support max 32GB	
Alarm and Event		
Alarm Trigger	Intelligent video motion detection and external input	
Motion Detection	12 zones	
Alarm Event	Event server: FTP server, SMTP server, web browser	
Privacy Masking	3 zones	

# CAIPBC210T

[www.black.honeywell.com](http://www.black.honeywell.com)

## High Definition 720P H.264 IP Box Camera

Model	CAIPBC210T	CAIPBC210T-P
<b>Electrical</b>		
Power Supply	12VDC & 24VAC	
Power over Ethernet (PoE)	N/A	IEEE 802.3af
Power Consumption	4W (excluding external loading)	
<b>Mechanical</b>		
Dimensions	158(D) x 70(W) x 61(H)	
Weight	437g	
Lens Mount	CS mount	
Connector	RS485	
<b>Environmental</b>		
Operating Temperature	-10°C to +55°C	
Operating Humidity	0% to 90% relative humidity	
Storage Temperature	-20°C to +60°C	
<b>Viewing System</b>		
Browser	IE 6.0 or above	
<b>Software</b>		
Search and Installation	IP finder	
CMS	Honeywell Black™ CAIPC-CMS100	
<b>Regulatory</b>		
Certification	CE, FCC	

Note: Honeywell reserves the right, without notification, to make changes in product design or specifications.

## CAIPBC210T

[www.black.honeywell.com](http://www.black.honeywell.com)

### High Definition 720P H.264 IP Box Camera

#### DIMENSIONS

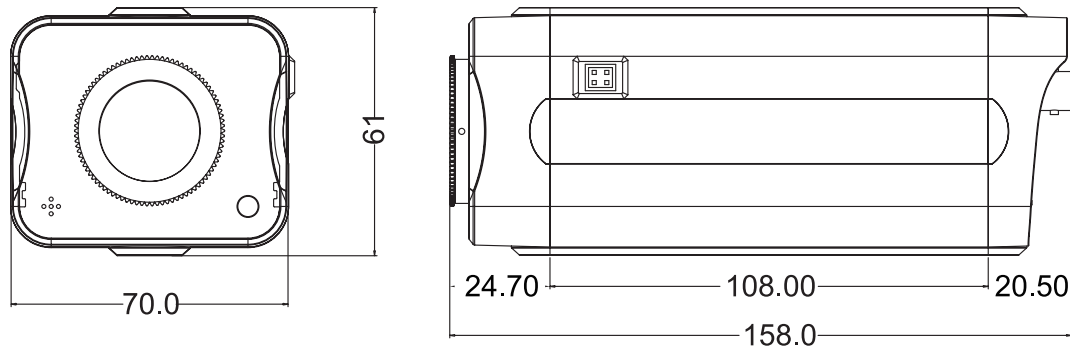

unit: mm

#### ORDERING

CAIPBC210T	720P IP Box Camera, TDN, H.264, 24VAC&12VDC, ONVIF
CAIPBC210T-P	720P IP Box Camera, TDN, H.264, 24VAC&12VDC and PoE IEEE 802.3af, ONVIF

For more information:

Security East Asia  
Security Pacific  
Security India  
Security Middle East & N.Africa  
Security Russia  
Security China  
Security Korea

Tel: (852) 2405 2323  
Tel: 1300 234 234  
Tel: (91) 124 4975000  
Tel: (971) 4454 1704  
Tel: (7) 495 7979371  
Tel: (86) 400 8800 330  
Tel: (82) 2799 6114

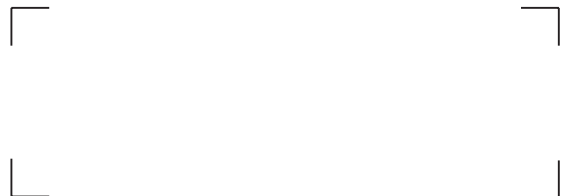

[www.black.honeywell.com](http://www.black.honeywell.com)  
[security.black@honeywell.com](mailto:security.black@honeywell.com)

Honeywell Security Group  
Automation & Control Solutions  
Honeywell International Inc.  
[www.security.honeywell.com](http://www.security.honeywell.com)



July 2014  
© 2014 Honeywell International Inc.