

V1492MP-G Series

Megapixel Integrated High-speed IP PTZ Camera System

Infinova[®]
The Integrator's Manufacturer

Features

- 20X HD integrated camera module, with resolution up to 1920x1080@25fps (PAL)/30fps (NTSC)
- Three Simultaneous Video Streams: Dual H.264 High profile & Scalable M-JPEG
- ONVIF-compliant
- Remote PTZ control, area zoom and image PTZ
- Web-based graphical OSD
- Timed Day/Night switch
- Local PC recording
- Support Presets, AutoPans, Patterns, AutoScan, Tour and Home Return
- High strength aluminum-alloy casting, heat-resistant, anti-corrosion
- Window wiper, built-in heater and window defroster/defogger
- Operational in 90mph wind conditions, withstanding wind velocity of up to 130mph
- IP66 environmental rating

Ordering Information

V1492MP-20G26H	Megapixel Integrated High-speed IP PTZ Camera System (2.0M, 20X, 1/2.8" progressive scan CMOS, day/night, H.264/MJPEG, 24VAC)
V1492MP-20G25H	Megapixel Integrated High-speed IP PTZ Camera System (2.0M, 20X, 1/2.8" progressive scan CMOS, day/night, H.264/MJPEG, 24VDC)
V1492MP-20G26S	Megapixel Integrated High-speed IP PTZ Camera System (2.0M, 20X, 1/2.8" progressive scan CMOS, day/night, H.264/MJPEG, 24VAC)
V1492MP-20G25S	Megapixel Integrated High-speed IP PTZ Camera System (2.0M, 20X, 1/2.8" progressive scan CMOS, day/night, H.264/MJPEG, 24VDC)

Accessories

V1662-W1:	Wall Mount, 15"
V1662-S1:	Pole Side Mount, 15"
V1662-C1:	Corner Mount

Dimensions

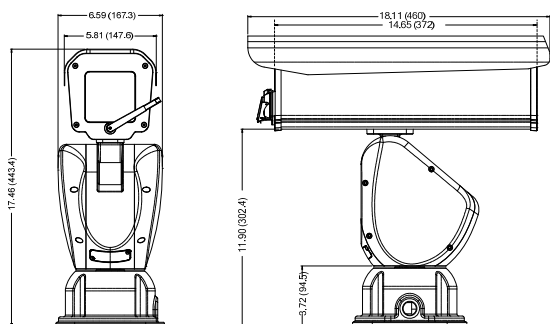

Front View

Side View

(Unit: inch, in the parentheses is mm)



Description

Infinova's V1492MP-G series megapixel integrated high-speed IP PTZ camera system provides you with a set of full digital real-time image acquisition system, featuring high definition, high frame rate and excellent signal-to-noise ratio.

V1492MP-G series support to browse and control H.264 High profile/M-JPEG encoded HD videos, with the resolution up to 1920x1080@25fps (PAL)/30fps (NTSC). User-friendly GUI interface is designed for easy PTZ control and convenient camera parameters setting. Thus, it makes easier to set the PTZ and perform operations with a mouse than traditional keyboard. In addition, area zoom and image PTZ are also offered.

V1492MP-G series feature Presets, Patterns, AutoPans, AutoScan, Tour, etc.

A powder-coated aluminum construction makes the PTZ camera system ideal for either indoor or outdoor applications. The system has an absolute operating temperature range of -40°F~140°F (-40°C~60°C). The built-in heater, defroster and defogger can be automatically enabled at a very low temperature to deal with the severe environment.

Mounting

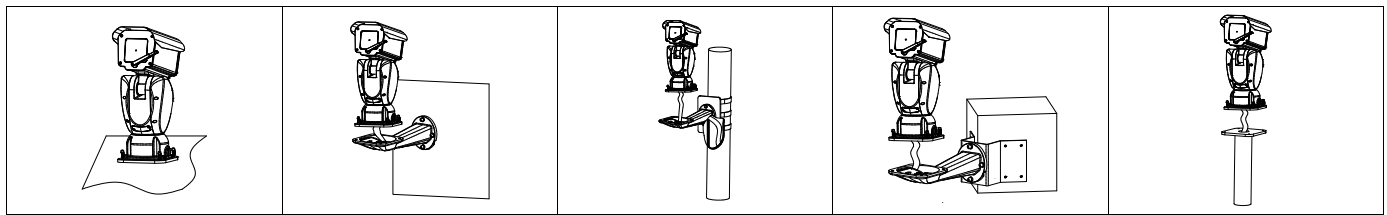

Surface Mount

Wall Mount

Pole Side Mount

Corner Mount

Pole Top Mount

Specifications

Model		V1492MP-20GH	V1492MP-20GS	
Lens	Optical Zoom	20X		
	Digital Zoom	/	12X	
	Aperture/Focal Length	F1.6~F3.5, f=4.7~94mm		
	Angle of View (H)	55.2°(Wide)~2.9°(Tele)	55.4°(Wide)~2.9°(Tele)	
	Min. Work Distance	0.01(Wide)~1.0(Tele)	0.01(Wide)~1.0 (Tele)	
Camera	Image Sensor	1/2.8" CMOS		
	Scanning System	Progressive scanning		
	Effective Resolution	2.0 Megapixel		
	S/N Ratio	>50dB		
	Sensitivity	Color mode: 1.6Lux@F1.6 (NTSC: 1/60s, PAL:1/50s) B/W mode: 0.04 Lux @F1.6 (NTSC: 1/4s, PAL:1/3s)	Color mode: 0.5 lux (1/30 sec., 50%, high sensitivity mode on) 0.08 lux (NTSC: 1/4sec; PAL: 1/3 sec, 50%, high sensitivity mode on) B/W mode: 0.095 lux (1/30 sec., 50%, high sensitivity mode on) 0.005 lux (NTSC: 1/4sec; PAL: 1/3 sec, 50%, high sensitivity mode on)	
	Sync System	Internal		
Functions	Programmable Presets	1~255		
	Programmable Patterns	4		
	Programmable Autopans	4		
	Tours	6 (each tour can be associated with 14 acts, including preset 1~32, pattern 1~4, autopan 1~4)		
	Home Return	Yes		
	Auto Scan	Yes		
	Iris	Auto, Manual, M/A		
	Focus	Auto, Manual, M/A		
	Shutter	Auto (1/1.5s~1/30,000s, adjustable)	Auto (1/1s~1/10000s, adjustable)	
	DSS	Yes		
	Image Mirror	Off/Horizontal/Vertical/Origin		
	Image Freeze	Yes		
	DNR	Yes		
	White Balance	Auto/Manu/Sodium/Mercury	Auto/Manu/Indoor/Outdoor/ATW/Outdoor Auto/Sodium Auto	
	AGC	Yes		
WDR	OFF, WDR, WDR*, AD WDR and AD WDR*	On/Off/Auto		

Model		V1492MP-20GH	V1492MP-20GS
	Backlight Compensation	On/Off	
	Area Zoom	Yes	
	Others	Hue, Saturation, Sharpness adjustable	
	Web server	Yes	
	Remote Upgrade	Yes	
Video	Compression	H.264 High profile/M-JPEG	
	Max. Resolution	1920×1080@25fps(50Hz)/30fps(60Hz)	
	Data Rate	1Mbps~8Mbps	
	Network Delay	<300ms	
IP	Network Port	1 RJ45 10/100M self-adaptive Ethernet port	
	Network Protocol	TCP/IP, HTTP, ICMP, UDP, SMTP, RTP, RTSP, SNMP, ARP	
Mechanical	Construction	High-strength aluminum alloy, stainless steel	
	Environmental Rating	IP66	
	Mounting	Surface mount, wall mount, pole side mount, corner mount, pole top mount	
	Variable Pan/Tilt Speed	Pan: 0.1°~50°/s; Tilt: 0.1°~45°/s	
	Preset Speed	Pan: 85°/s (maximum); Tilt: 40°/s (maximum)	
	Pan Rotation Angle	360° continuous rotation	
	Tilt Rotation Angle	+40°~-90°	
Electrical	Input Voltage and Power Consumption	24VAC:<65W(heater On); 24VDC: 55W(heater On)	
Environmental	Atmospheric Pressure	≤1.5MPa	
	Operating Temperature	-40°F~140°F (-40°C~+60°C)	
	Storage Temperature	-40°F~140°F (-40°C~+60°C)	
	Operating Humidity	0~95%RH (non-condensing)	
	Heater	Thermostatically controlled; Turns on at 50°F ± 9°F (10°C ± 5°C); Turns off at 86°F ± 9°F (30°C ± 5°C)	
Physical	Load	Pan: 22lbs (10kg); Tilt: 7.7lbs (3.5kg)	
	Weight	21.61 lbs (9.8kg)	
	Shipping Weight	31.31 lbs (14.2kg)	
	Box Dimension (L×W×H)	22.99"×16.81"×10.00" (584mm×427mm×254mm)	
Compliance	CE, FCC, ISO 9001: 2008		