

SN-IPS57/20MDR/ZSC30

2MP Network IR High Speed Dome



- 1/2.8" Progressive Scan CMOS
- 30X Optical Zoom, 16X Digital Zoom
- HD 2MP(1920×1080)@60fps
- Multiple Streams
- Smart IR Range 200m
- Auto Tracking
- 3D DNR, WDR, ICR, IVS
- Auto Tracking
- IP66

System Overview

Featuring powerful optical zoom and accurate pan/tilt/zoom performance, this camera can provide large monitoring range and great detail. The camera has very excellent low light performance due to adopting the latest starlight technology. The camera is equipped with smooth control, high quality image and good protection, which make it can meet most of the requirements of video surveillance applications.

Functions

Auto-tracking

This feature controls the pan/tilt/zoom actions of the camera to automatically track an object in motion and to keep it in the scene. The tracking action can be triggered manually or automatically by defined rules. Once a rule is triggered, the camera can zoom in and track the defined target automatically.

Intelligent Video System (IVS)

With built-in intelligent video analytics, the camera has the ability to detect and analyze moving objects for improved video surveillance. The camera provides optional standard intelligence at the edge allowing detection of Perimeter, Single Virtual Fences, Double Virtual Fences Loiter, Multi Loiter, Object Left, Object Removed, Abnormal Speed, Converse, Illegal Parking, and Signal Bad.

Smart Encode (H.265+)

Deliver high quality video without straining the network, Smart Encode H.265+ is the optimized implementation of H.265. The Smart H.265+ encoding technology includes a scene adaptive encoding strategy, dynamic GOP, dynamic ROI, flexible multi-frame reference structure and intelligent noise reduction, providing saving of up to 70% of bandwidth and storage when compared with standard H.265.

Environmental

Sunell cameras operate in extreme temperature environments, rated for use in temperatures from -55°C ~ 60°C (-67°F ~ +140°F) with 90% humidity. Subjected to rigorous dust and water immersion tests and certified to the IP66 Ingress Protection rating makes it suitable for demanding outdoor applications.

Protection

The camera allows for ±20% input voltage tolerance, suitable for the unstable conditions for outdoor applications. Its 6KV lightning rating provides effective protection for both the camera and its structure against lightning.

Technical Specification

Camera	
Image Sensor	1/2.8" Progressive Scan CMOS
Effective Pixels	1920(H) x 1080(V)
Scanning System	Progressive
Electronic Shutter	Auto/Manual, 1/5~1/20,000s
Min. illumination	Color:0.01Lux@(F1.2,AGC ON) ; B/W:0Lux@(IR LED ON)
S/N Ratio	55dB
IR Distance	Smart IR up to 200m
IR On/Off Control	Auto/Manual
IR LEDs	10pcs
Lens	
Focal Length	4.5~135mm
Max. Aperture	F1.6~F4.4
Angle of View	H: 59.8°~2.3°
Optical Zoom	30x
Focus Control	Auto/Manual
Close Focus Distance	1000mm~1500mm
PTZ	
Pan/Tilt Range	Pan: 0° ~ 360° endless, Tilt: -10° ~ +90°
Manual Control Speed	Pan: 0.1° ~180° /s, Tilt: 0.1° ~90° /s
Preset Speed	Pan: 180° /s, Tilt: 90° /s
Presets	400
PTZ Mode	6 Track, 12 Tour, 12 Scan,
Speed Setup	Auto/Manual (0-8)
Power up Action	Support
Idle Motion	Activate Preset/ Scan/ Tour/ Track if there is no command in the specified period
Intelligence	
Auto Tracking	Support
IVS	Perimeter, Single Virtual Fences, Double Virtual Fences, Loiter, Multi Loiter, Object Left, Object Removed, Abnormal Speed, Converse, Illegal Parking, Signal Bad
Video	
Compression	H.265, H.264, MJPEG
Streaming Capability	3 Streams
Stream / Frame Rate	Stream1: 1920x1080/1280x720 @50/60fps Stream2: D1/VGA/640x360/CIF/QVGA @25/30fps Stream3: VGA/CIF/QVGA @25/30fps

Bit Rate Control	CBR/VBR
Bit Rate	Stream1: 200kbps~12Mbps Stream2: 100kbps~6Mbps Stream3: 100kbps~6Mbps
Day/Night	Auto(ICR) / Color / B/W
Image Enhancement	BLC/HLC/WDR(120dB)
White Balance	Auto/Tungsten/Fluorescent/Daylight/Shadow/Manual
Gain Control	Auto/Manual
Noise Reduction	2D/3D DNR
Electronic Image Stabilization(EIS)	N/A
Defog	Yes
Digital Zoom	16x
Mirror	Support
Region of Interest	Off / On (8 Zone)
Motion Detection	Off / On
Privacy Masking	Off / On (4 Area, Rectangle)
Audio	
Compression	G.711, RAM_PCM
Bit Rate	8kbps (G.711), 16kps (RAW_PCM)
Network	
Ethernet	RJ-45 (10/100Base-T)
Protocols:	IPv4/IPv6, 802.1x, HTTP, HTTPS, TCP/IP, UDP/IP, RTSP, DHCP, NTP, RTCP/RTP, PPPoE, SMTP, DNS, UPnP, FTP, APR, SNMP
Interoperability	ONVIF, CGI, SDK
Streaming Method	Unicast
Max. User Access	10 Users
Edge Storage	NAS Local PC for instant recording Micro SD card 128GB
Web Viewer	<IE11, Chrome, Firefox
Management Software	SunView
Smart Phone	IOS, Android
Interface	
Ethernet	1 Ethernet (10/100 Base-T) RJ-45 Connector
Audio Interface	1ch Audio In,1ch Audio Out
Alarm	7ch Alarm In,2ch Alarm Out
RS485	Yes
BNC Output	Yes
Reset Button	Yes(Built-in)

General	
Power Supply	AC24V/Hi-POE (Adapter optional)
Power Consumption	Less than 40W
Operating Temperature	Starting Temperature: -40°C ~ 60°C (-40°F ~ 140 °F) Working Temperature:-55°C ~ 60°C (-67°F ~ 140 °F)
Storage Conditions	Less than 90% RH
Ingress Protection	IP66,TVS4000V
Certifications	CE/FCC
Casing	Metal
Dimensions	Φ226x362.8mm
Net Weight	5.2Kg

Dimensions(mm)

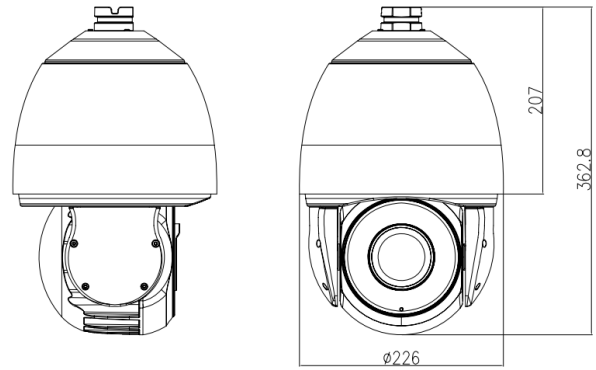

Accessories

Optional:



SN-BK349
Wall Bracket



SN-BK348
Ceiling Bracket



SN-BK605
Corner Mount



SN-BK604B
Pole Mount