



LNX-C800 Series

**8-Port Compact Industrial Unmanaged Ethernet Switch, with
8*10/100Tx**



User Manual

Version 1.2
(September 2020)

© Copyright 2020 Antaira Technologies, LLC.

All Rights Reserved

This document contains information, which is protected by copyright. Reproduction, adaptation or translation without prior permission is prohibited, except as allowed under the copyright laws.

Trademark Information

Antaira is a registered trademark of Antaira Technologies, LLC, Microsoft Windows and the Windows logo are the trademarks of Microsoft Corp. NetWare is the registered trademark of Novell Inc. WMM and WPA are the registered trademarks of Wi-Fi Alliance. All other brand and product names are trademarks or registered trademarks of their respective owners.

Notice: Copyrights © 2020 by Antaira Technologies, LLC. All rights reserved. Reproduction, adaptation, or translation without prior permission of Antaira Technologies, LLC. is prohibited, except as allowed under the copyright laws.

Disclaimer

Antaira Technologies, LLC. provides this manual without warranty of any kind, expressed or implied, including but not limited to the implied warranties of merchantability and fitness for a particular purpose. Antaira Technologies, LLC. may make improvements and/or changes to the product and/or specifications of the product described in this manual, without prior notice. Antaira Technologies, LLC. will not be liable for any technical inaccuracies or typographical errors found in this guide. Changes are periodically made to the information contained herein and will be incorporated into later versions of the manual. The information contained is subject to change without prior notice.

FCC Warning

This equipment has been tested and found to comply with the limits for a Class-A digital device, pursuant to Part 15 of the FCC rules. These limits are designed to provide reasonable protection against harmful interference in a residential installation. This equipment generates, uses, and can radiate radio frequency energy. It may cause harmful interference to radio communications if the equipment is not installed and used in accordance with the instructions. However, there is no guarantee that interference will not occur in a particular installation. If this equipment does cause harmful interference to radio or television reception, which can be determined by turning the equipment off and on, the user is encouraged to try to correct the interference by one or more of the following measures:

- Reorient or relocate the receiving antenna.
- Increase the separation between the equipment and receiver.
- Connect the equipment into an outlet on a circuit different from that to which the receiver is connected.
- Consult the dealer or an experienced radio/TV technician for help.

Caution: Any changes or modifications not expressly approved by the grantee of this device could void the user's authority to operate the equipment.

Avertissement FCC

Cet équipement a été testé et déclaré conforme aux limites d'un appareil numérique de classe A, conformément à la partie 15 des règles de la FCC. Ces limites sont conçues pour fournir une protection raisonnable contre les interférences nuisibles dans une installation résidentielle. Cet équipement génère, utilise et peut émettre de l'énergie radiofréquence. Cela peut provoquer des interférences nuisibles aux communications radio si l'équipement n'est pas installé et utilisé conformément aux instructions.

Cependant, il n'y a aucune garantie qu'aucune interférence ne se produira dans une installation particulière. Si cet équipement provoque des interférences nuisibles à la réception radio ou télévision, ce qui peut être déterminé en éteignant puis en rallumant l'équipement, l'utilisateur est encouragé à essayer de corriger les interférences par une ou plusieurs des mesures suivantes:

- Réorientez ou déplacez l'antenne de réception.
- Augmentez la distance entre l'équipement et le récepteur.
- Connectez l'équipement à une prise sur un circuit différent de celui auquel le récepteur est connecté.
- Consultez le revendeur ou un technicien radio / TV expérimenté pour obtenir de l'aide.

Attention: Tout changement ou modification non expressément approuvé par le bénéficiaire de cet appareil peut annuler le droit de l'utilisateur à utiliser l'équipement.

CE Mark Warning

This is a Class-A product. In a domestic environment this product may cause radio interference in which case the user may be required to take adequate measures.

Avertissement de marque CE

Ceci est un produit de classe A. Dans un environnement domestique, ce produit peut provoquer des interférences radio, auquel cas l'utilisateur peut être amené à prendre des mesures adéquates.

Industrial Ethernet Switches

Industrial Grade Unmanaged Ethernet Switches

User Manual

Version 1.2 (September 2020)

This manual supports the following models:

- LNX-C800
- LNX-C800(-T)

This document is the current official release manual. Please check our website (www.antaira.com) for any updated manual or contact us by e-mail (support@antaira.com).

Table of Contents

1.	Overview	1
1.1	Key Features	1
1.2	Package Contents	1
1.3	Safety Precaution	2
2.	Hardware Description	3
2.1	Physical Dimensions	3
2.2	Front Panel	4
2.3	Top View	4
2.4	LED Indicators	5
2.5	Ethernet Ports	5
2.6	Cabling	7
2.7	Wiring the Power Inputs	7
2.8	Wiring the Fault Alarm Contact	8
2.9	Grounding Note	9
3.	Mounting Installation	10
3.1	DIN-Rail Mounting	10
3.2	Wall Mounting.....	11
4.	Hardware Installation	12
4.1	Installation Steps	12
4.2	Maintenance and Service	13
4.3	Trouble Shooting	13
5.	Technical Specifications	14

1. Overview

Antaira Technologies' LNX-C800 series is a compact 8-port industrial Ethernet switch. The small form factor of this metal IP30 rated industrial switch is 30% smaller allowing for a more versatile implementation. The LNX-C800 series is equipped with 8*10/100Tx RJ45 Ethernet ports. The industrial-grade design and compact size of the LNX-C800 series make this the ideal unit for integration into projects or other applications that need a small footprint.

The LNX-C800 series supports reverse polarity and overload current protection. This product series supports DIN-rail as well as wall mountable orientations and provides operating temperature range models in STD: -10°C to 65°C and EOT: -40°C to 75°C. This is an industrial grade unit applicable for networking applications in factory automation, ITS, power/utility, water wastewater treatment plants, or any application that needs a compact solution.

1.1 Key Features

- System Interface/Performance
 - All RJ-45 ports support the auto MDI/MDI-X function
 - Embedded 8*10/100Tx
 - Store-and-forward switching architecture
 - 1K MAC address table
- Power Input
 - DC 12~48V redundant power with a 6-pin removal terminal block
- Operating Temperature
 - Standard operating temperature model: -10°C ~ 65°C
 - Extended operating temperature model (-T): -40°C ~ 75°C
- Case/Installation
 - IP30 protection
 - DIN-Rail and wall mount design

1.2 Package Contents

- 1 - LNX-C800(-T): 8-port industrial compact unmanaged Ethernet switch with 8*10/100Tx

- 2 - Wall mounting brackets and screws
- 1 - DC cable –18 AWG & DC jack 5.5x2.1mm
- 1 – Quick Installation Guide
- 1 – RJ45 dust cover set

1.3 Safety Precaution

Attention: If the DC voltage is supplied by an external circuit, please use a protection device on the power supply input. The industrial Ethernet switch's hardware specs, ports, cabling information, and wiring installation will be described within this user manual.

Attention: Si la tension CC est fournie par un circuit externe, veuillez utiliser un dispositif de protection sur l'entrée d'alimentation. Les spécifications matérielles, les ports, les informations de câblage et l'installation du câblage du commutateur Ethernet industriel seront décrits dans ce manuel d'utilisation.

Warning Labels

The caution label means that you should check the certain information on user manual when working with the device. (Shown in Figure 1.1)

Étiquettes d'avertissement

L'étiquette d'avertissement signifie que vous devez vérifier certaines informations sur le manuel d'utilisation lorsque vous travaillez avec l'appareil. (Montré dans la figure 1.1)



Figure 1.1 - Caution Label

Figure 1.1 - Étiquette de mise en garde



Figure 1.2 - Hot Surface Warning Label

Figure 1.2 - Étiquette d'avertissement de surface chaude

2. Hardware Description

2.1 Physical Dimensions

Figure 2.1, below, shows the physical dimensions of Antaira Technologies' LNX-C800 series: 8-port compact industrial unmanaged Ethernet switch with 8*10/100Tx RJ45 ports.

(W x D x H) is 40mm x 70mm x 95mm

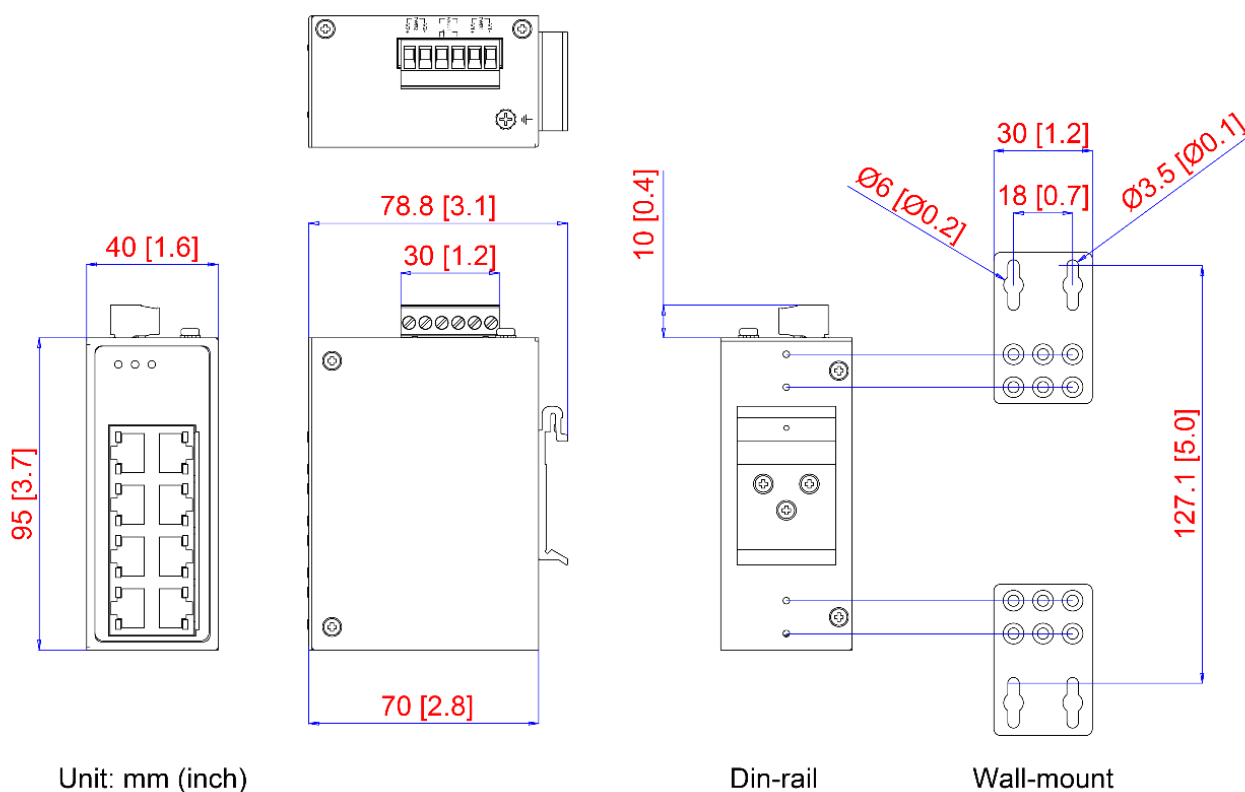

Figure 2.1

LNX-C800 Series Physical Dimensions

2.2 Front Panel

The front panel of the LNX-C800 series: 8-port industrial compact unmanaged Ethernet switch with 8*10/100Tx. See Figure 2.2.

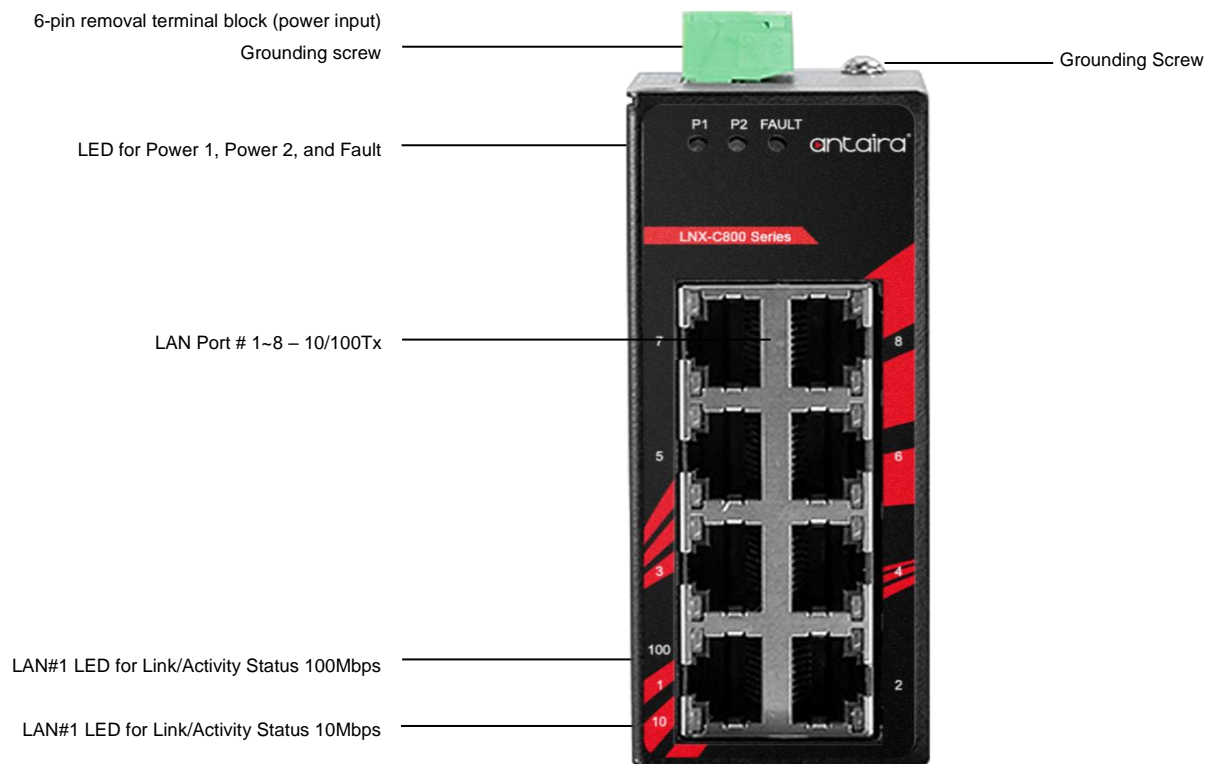

Figure 2.2 - Front Panel of the LNX-C800 Series

2.3 Top View

Figure 2.3, below, shows the top panel of the LNX-C800 series switch that is equipped with one 6-pin removal terminal block connector for dual DC power inputs (12-48 VDC).

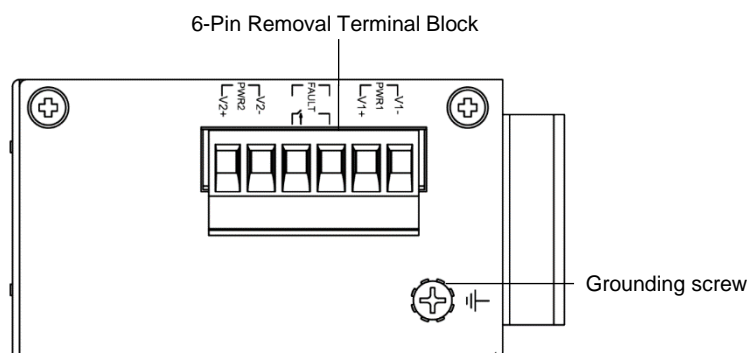

Figure 2.3

Top Panel View of LNX-C800 Series

2.4 LED Indicators

There are LED light indicators located on the front panel of the industrial Ethernet switch that display the power status and network status. Each LED indicator has a different color and has its own specific meaning, see below in *Table 2.4*.



LED	Color	Description	
Power	Green	On	Power input is active
		Off	Power input is inactive
LAN Port 1 ~ 8 (Left LED)		On	Connected to network, 100Mbps
		Flashing	Networking is active
		Off	Not connected to network
LAN Port 1 ~ 8 (Right LED)		On	Connected to network at 10Mbps
		Flashing	Networking is active
		Off	Not connected to network

Table 2.4

LED Indicators for LNX-C800 Series

2.5 Ethernet Ports

■ RJ-45 Ports

RJ-45 Ports (Auto MDI/MDIX): The RJ-45 ports (LAN 1~8) are auto-sensing for 10/100Base-T, or 100Base-Tx devices connections. Auto MDI/MDIX means that the switch can connect to another switch or workstation without changing the straight-through or crossover cabling. See the figures shown below for straight-through and crossover cabling schematics.

■ RJ-45 Pin Assignments

Pin Number	Assignment
1	Rx+
2	Rx-
3	Tx+
6	Tx-

Table 2.5 - RJ45 Pin Assignments

Note: The “+” and “-” signs represent the polarity of the wires that make up each wire pair.

All ports on this industrial Ethernet switch support automatic MDI operations. Users can use straight-through cables (see figure below) for all network connections to PCs, servers, and other switches or hubs. With straight-through cable, pins 1, 2, 3, and 6, at one end of the cable, are connected straight through to pins 1, 2, 3 and 6 at the other end of the cable. The table below shows the 10BASE-T/100BASE-TX MDI port pin outs.

Pin MDI-X	Signal Name	MDI Signal Name
1	Receive Data plus (RD+)	Transmit Data plus (TD+)
2	Receive Data minus (RD-)	Transmit Data minus (TD-)
3	Transmit Data plus (TD+)	Receive Data plus (RD+)
6	Transmit Data minus (TD-)	Receive Data minus (RD-)

Table 2.6 - Ethernet Signal Pin Outs

The following figures show the cabling schematics for straight-through and crossover cables.

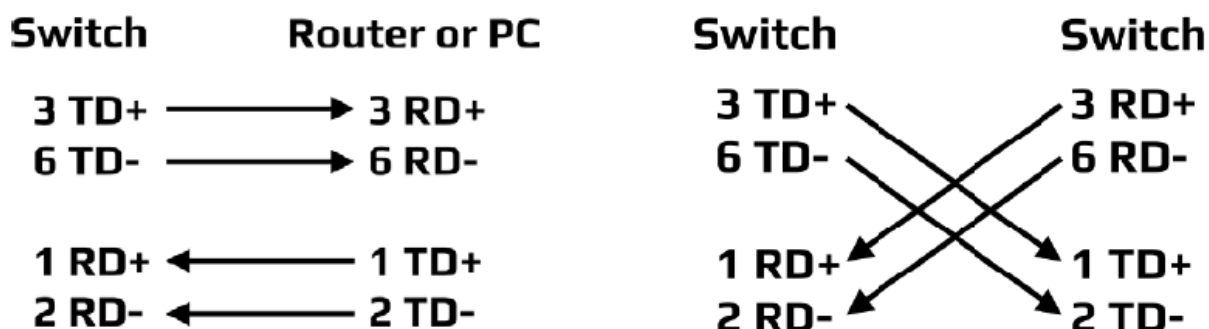

2.6 Cabling

- Twisted-pair segments can be connected with an unshielded twisted pair (UTP) or shielded twisted pair (STP) cable. The cable must comply with the IEEE 802.3u 100Base TX standard (e.g. Category 5, 5e, 6, or 6a). The cable between the equipment and the link partner (switch, hub, workstation, etc.) must be less than 100 meters (328 ft.) long.

Note: Cable size should be between 18~20 AWG and the torque should be tightened to 5lbs.

2.7 Wiring the Power Inputs



Caution: Please follow the steps below when inserting the power wire.



Attention: Veuillez suivre les étapes ci-dessous lors de l'insertion du câble d'alimentation.

1. Insert the positive and negative wires into the PWR1 (V1+, V1-) and PWR2 (V2+, V2-) contacts on the terminal block connector as shown below in *Figure 2.7.1*

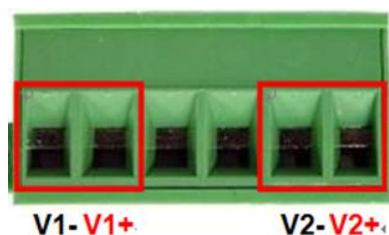

Figure 2.7.1

Power Terminal Block

2. Tighten the wire-clamp screws to prevent the wires from loosening, as shown below in *Figure 2.7.2*



Figure 2.7.2

Power Terminal Block



Caution:

- Only use copper conductors, **125°C**, tighten to **5 lbs.**
- The wire gauge for the terminal block should range between **18~20 AWG**.



Attention:

- Utilisez uniquement des conducteurs en cuivre, **125°C**, serrez à **5 lb.**
- Le calibre des fils du bornier doit être compris entre **18 et 20 AWG**.

2.8 Wiring the Fault Alarm Contact

The fault alarm contact is in the middle of the terminal block connector as the picture shows below in *Figure 2.8*. By inserting the wires, it will detect the fault status including power failure or port link failure (managed industrial switch only) and form a normal open circuit. An example is shown below in *Figure 2.8*.

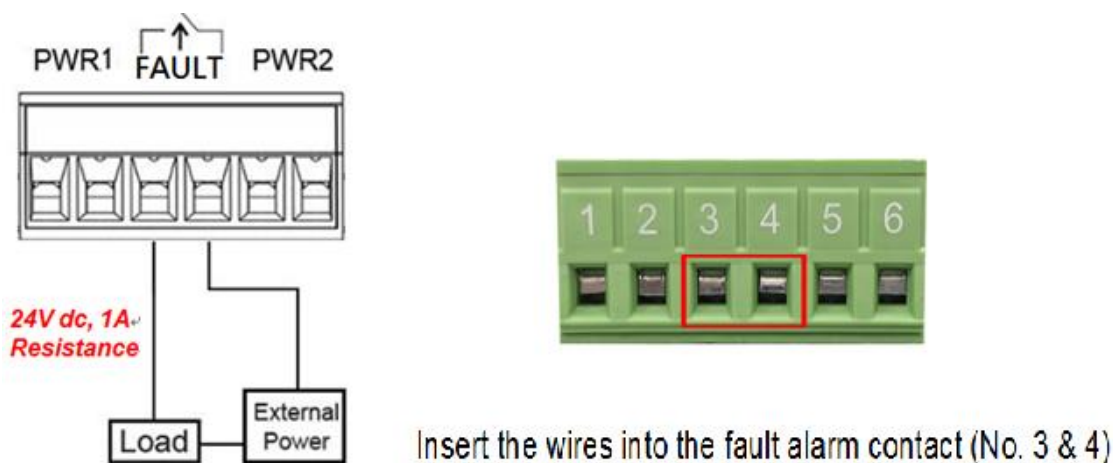

Figure 2.8

Wiring the Fault Alarm Contact



Caution:

- The wire gauge for the terminal block should range between **12 ~ 24 AWG**.
- If only using one power source, jumper **Pin 1 to Pin 5** and **Pin 2 to Pin 6** to eliminate power fault alarm.



Attention:

- Le calibre des fils du bornier doit être compris entre **12 et 24 AWG**.
- Si vous n'utilisez qu'une seule source d'alimentation, connectez les broches **1 à 5** et les broches **2 à 6** pour éliminer l'alarme de panne de courant.

2.9 Grounding Note

Grounding and wire routing help limit the effects of noise due to Electromagnetic Interference (EMI). Run the ground connection from the ground screw to the grounding surface prior to connecting devices. The grounding screw symbol is shown below in *Figure 2.9*.

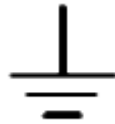

Figure 2.9 - Grounding screw symbol



Caution: Using a shielded cable achieves better electromagnetic compatibility.



Attention: L'utilisation d'un câble blindé permet une meilleure compatibilité électromagnétique.

3. Mounting Installation

3.1 DIN-Rail Mounting

The DIN-Rail is pre-installed on the industrial Ethernet switch from the factory. If the DIN-Rail is not on the industrial Ethernet switch, please refer to *Figure 3.1* to learn how to install the DIN-Rail on the switch.

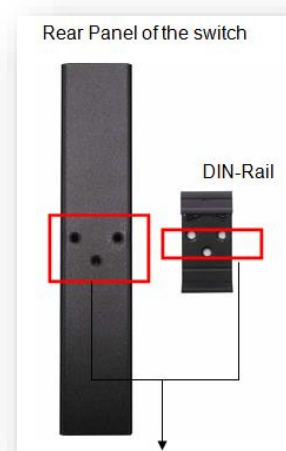

Figure 3.1.1

The Rear Side of the Switch and DIN-Rail Bracket

Follow the steps below to learn how to hang the industrial Ethernet switch.

1. Use the screws to install the DIN-Rail bracket on the rear side of the industrial Ethernet switch.
2. To remove the DIN-Rail bracket, do the opposite from step 1.
3. After the DIN-Rail bracket is installed on the rear side of the switch, insert the top of the DIN-Rail on to the track as shown below in *Figure 3.1.2*
4. Lightly pull down the bracket on to the rail as shown below in *Figure 3.1.3*
5. Check if the bracket is mounted tightly on the rail.
6. To remove the industrial Ethernet switch from the rail, do the opposite from the above steps.



Figure 3.1.2

Insert the Switch on the DIN-Rail

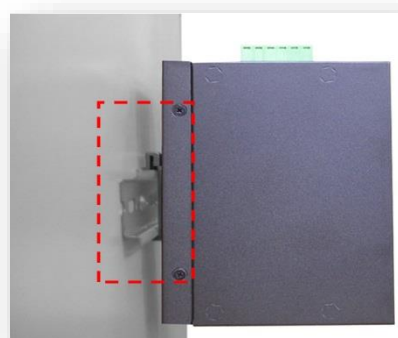

Figure 3.1.3

Stable the Switch on DIN-Rail

7. Check if the bracket is mounted tightly on the rail.
8. To remove the industrial Ethernet switch from the rail, do the opposite from the above steps.

3.2 Wall Mounting

Follow the steps below to mount the industrial Ethernet switch using the wall mounting bracket as shown below in *Figure 3.2*.



Caution: “Wall” means industrial control panel wall



Attention: “Wall” signifie mur de panneau de commande industriel

1. Remove the DIN-Rail bracket from the industrial Ethernet switch by loosening the screws.
2. Place the wall mounting brackets on the top and bottom of the industrial Ethernet switch.
3. Use the screws to screw the wall mounting bracket on the industrial Ethernet switch.



Caution: The torque for tightening the screws on the device is 3.5 in-lbs.



Attention: Le couple de serrage des vis sur l'appareil est de 3.5 pouces-livres.

4. Use the hook holes at the corners of the wall mounting bracket to hang the industrial Ethernet switch on the wall.
5. To remove the wall mount bracket, do the opposite from the steps above.

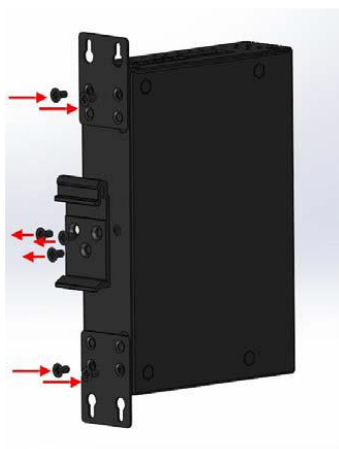

Figure 3.2 - Remove DIN-Rail Bracket from the Switch

Below, in *Figure 3.3* are the dimensions of the wall mounting bracket.

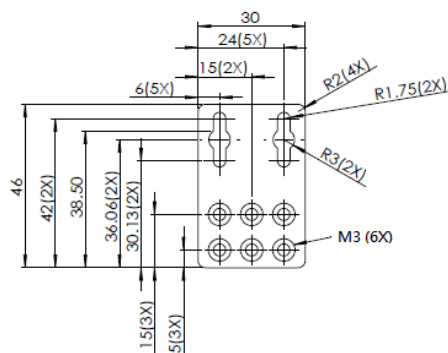

Figure 3.3 - Wall Mounting Bracket Dimensions

4. Hardware Installation

4.1 Installation Steps

This section will explain how to install Antaira's LNX-C800(-T):



Caution: This device is intended for use indoor.



Attention: Cet appareil est destiné à être utilisé à l'intérieur.



Caution: The device is intended to be installed in an industrial control enclosure and panel.



Attention: L'appareil est destiné à être installé dans une armoire de commande et un panneau industriels.

Installation Steps

1. Unpack the industrial Ethernet switch from the original packing box.
2. Check if the DIN-Rail bracket is screwed on the industrial Ethernet switch.
 - If the DIN-Rail is not screwed on the industrial Ethernet switch, please refer to the **DIN-Rail Mounting** section for DIN-Rail installation.
 - If it is required to wall mount the industrial Ethernet switch, please refer to the **Wall Mounting** section for wall mounting installation.
3. To hang the industrial Ethernet switch on a DIN-Rail or wall, please refer to the **Mounting Installation** section.
4. Power on the industrial Ethernet switch and then the power LED light will turn on.
 - For the help on how to wire power, please refer to the **Wiring the Power Inputs** section.
 - Please refer to the **LED Indicators** section for LED light indication.
5. Prepare the twisted-pair, straight-through category 5 cable for Ethernet connection.
6. Insert one side of the RJ-45 cable into the switch's Ethernet port and on the other side into the networking device's Ethernet port, e.g. switch PC or server.
 - The Ethernet port's (RJ-45) LED on the industrial Ethernet switch will turn on when the cable is connected to the networking device.
 - Please refer to the **LED Indicators** section for LED light indication.
7. When all connections are set and the LED lights all show normal, the installation is complete.

4.2 Maintenance and Service

- If the device requires servicing of any kind, the user is required to disconnect and remove it from its mounting. The initial installation should be done in a way that makes this as convenient as possible.
- Voltage/Power lines should be properly insulated as well as other cables. Be careful when handling them so as to not trip over.
- Do not under any circumstance insert foreign objects of any kind into the heat dissipation holes located in the different faces of the device. This may not only harm the internal layout, but might cause harm to user as well.
- Do not under any circumstance open the device for any reason. Please contact your dealer for any repair needed or follow the instructions within the manual.
- Clean the device with dry soft cloth.

4.3 Trouble Shooting

- Always verify the right power cord or adapter is being used. Never use a power supply or adapter with a non-compliant DC output voltage or it will burn the equipment.
- Select the proper UTP or STP cable in order to construct the network. Use an unshielded twisted-pair (UTP) or shield twisted-pair (STP) cable for RJ-45 connections: 100Ω Category 5e for 10/100Mbps. Also be sure that the length of any twisted-pair connection does not exceed 100 meters (328 feet).
- **Diagnosing LED Indicators:** To assist in identifying problems, the switch can be easily monitored with the LED indicators which help to identify if any problems exist.
 - Please refer to the LED Indicators section for LED light indication.
- If the power indicator LED does not turn on when the power cord is plugged in, the user may have a problem with the power cord. Check for loose power connections, power losses or surges at the power outlet.
 - Please contact Antaira for technical support service, if the problem still cannot be resolved.
- If the industrial switch LED indicators are normal and the connected cables are correct but the packets still cannot transmit, please check the system's Ethernet devices' configuration or status.

5. Technical Specifications

Table 6.1 has the technical specifications for Antaira Technologies' LNX-C800 series: 8-port industrial unmanaged Ethernet switch with 8*10/100Tx ports.

Standards	IEEE 802.3	10Base-T 10Mbit/s Ethernet
	IEEE 802.3u	100Base-Tx, 100Base-Fx, Fast Ethernet
Switch Property	Protocol	CSMA/CD
	Data Process	Store and Forward
	Transfer Rate	14,880 pps for 10Base-T Ethernet port 148,800 pps for 100Base-TX Fast Ethernet port
	Transmission Distance	Up to 100M (Fast Ethernet)
	Transmission Speed	Up to 100Mbps (Fast Ethernet)
	MAC Address Table	1K table size
Port Interface	Ethernet (RJ45) Port	8*10/100Tx auto negotiation speed, full/half duplex mode, and auto MDI/MDI-X connection
	LED Indicator	Per unit: Power1 (Green), Power2 (Green), Fault (Red) Per port: Link/Activity (Green)
	Network Cable	10BaseT: 2-pair UTP/STP Cat.3,4,5 cable EIA/TIA-568 100-ohm (100m) 100BaseTX: 2-pair UTP/STP Cat.5 cable EIA/TIA-568 100-ohm (100m)
Mechanical Characteristics	Housing	Metal IP30 protection
	Dimension	40 x 70 x 95 mm (w x d x h)
	Weight	Unit Weight: 0.74 lb. Shipping Weight: 1.05 lbs.
	Mounting	DIN-Rail Mounting, wall-mounting (optional)
Power Requirement	Input Voltage	12~48VDC Redundant Input
	Current Protection	Present – Slow Blow Fuse
	Power Connection	1 removable 6-contact terminal block
	Power Consumption	2.2 Watts
Environmental Limits	Operating Temperature	Standard: -10°C to 65°C (14°F to 149°F) EOT: -40°C to 75°C (-40°F to 167°F)
	Operating Humidity	5% to 95% (Non-Condensing)
	Storage Temperature	-40°C to 85°C (-40°F ~ 185°F)
Regulatory Approvals	EMI	FCC Part 15 Subpart B Class A, CE EN55032/EN61000-6-4 Class A
	EMS	CE EN55035/EN61000-6-2 Class A, IEC61000-4-2,3,4,5,6,8
	Stability Testing	IEC60068-2-32 (Free Fall) IEC60068-2-27 (Shock) IEC60068-2-6 (Vibration)
	Certifications	FCC, CE, UL 61010-1, UL 61010-2-201
	Warranty	5 Years

Table 6.1

LNX-C800 Series Technical Specifications

Antaira Customer Service and Support

(Antaira US Headquarter) + 844-268-2472

(Antaira Europe Office) + 48-22-862-88-81

(Antaira Asia Office) + 886-2-2218-9733

Please report any problems to Antaira:

www.antaira.com / support@antaira.com

www.antaira.eu / info@antaira.eu

www.antaira.com.tw / info@antaira.com.tw

Any changes to this material will be announced on the Antaira website.